

SunSpan™

HEATERS

Residential Garage Heater



APPLICATIONS*

- Home Garages ● Workshops
- Hobby Areas ● Entryways ● Clubhouses
- Farm Buildings ● Machine Shops

*Not for Indoor Living or Sleeping Areas

Enjoy the Comfort of Warm, Radiant Heat in Your Garage, Workshop, Entryway and Other Hard-to-Heat Spaces

Save up to **50%**
In Energy Costs

The SunSpan Residential Garage Heater packs a powerful amount of radiant energy into a compact, fuel efficient, stand-alone heater that will keep your garage or workshop comfortable all winter long. Powered by Natural gas or LP/Propane, its compact size, safe, quiet operation and easy installation also makes it an ideal source of radiant heat for use in a wide variety of hard-to-heat spaces.

Get the heat down where it counts

The Residential Garage Heater utilizes a highly polished 'Brite' aluminum reflector that may be rotated from 0° to 30° to direct the heat where needed to warm people, floors and work surfaces. Heat is absorbed by these surfaces and re-radiated back to warm the surrounding area by conduction and convection, similar to the sun's rays warming the earth.

High comfort ... Low cost

Experience for yourself the enjoyment of improved comfort levels plus annual fuel savings of up to 50% over conventional warm air units.

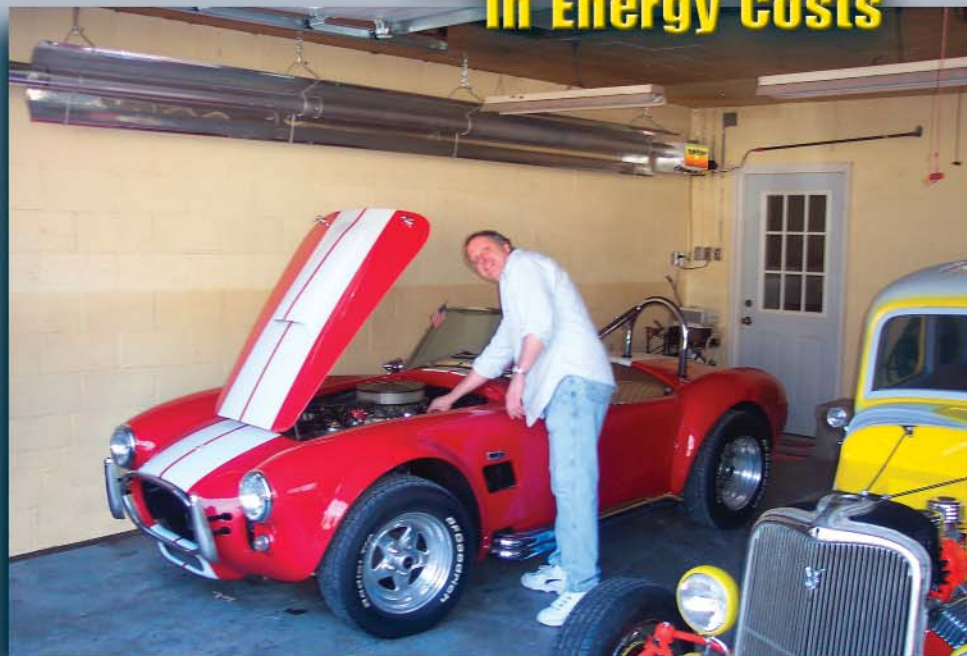

Drive home to the most comfortable parking spot. Heat your garage, workshop, or other hard-to-heat spaces with the affordable SunSpan Residential Garage Heater.

FEATURES

- Compact size to fit a wide variety of hard-to-heat spaces
- Fuel efficient operation: Choice of Natural gas or LP/propane models
- Simple chain mounting
- Corrosion resistant heat exchanger tube assures long system life
- 'Brite' aluminum rotatable reflector for even heat dispersion
- Durable direct spark ignition – 100% safety shut-off
- CSA international design certified to ANSI/CGA standards



Residential Garage Heater

STRAIGHT

MODEL	MBTUH	LENGTH "A" MIN.¹	LENGTH "A" MAX.¹	SHIP WT. (lbs.)
SRHS	40	10'	14' 9"	75-90
SRHS	45	19' 9"	19' 9"	110
SRHS	50	19' 9"	19' 9"	110
SRHS	55	19' 9"	19' 9"	110
SRHS	60	19' 9"	19' 9"	110

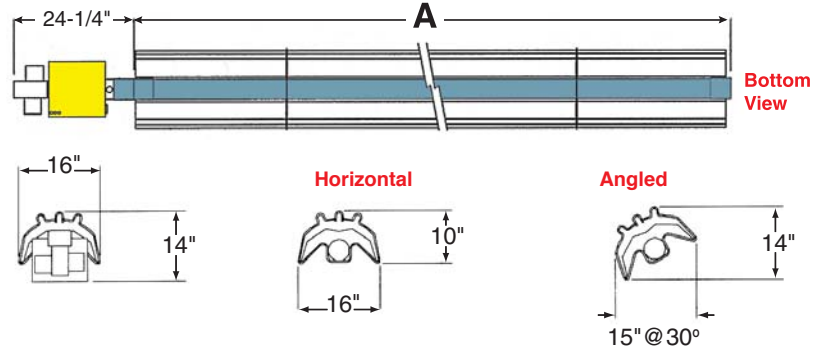

U-TUBE

MODEL	MBTUH	LENGTH "A"	SHIP WT. (lbs.)
SRHU	40	10'	90
SRHU	45	10'	110
SRHU	50	10'	110
SRHU	55	10'	110
SRHU	60	10'	110

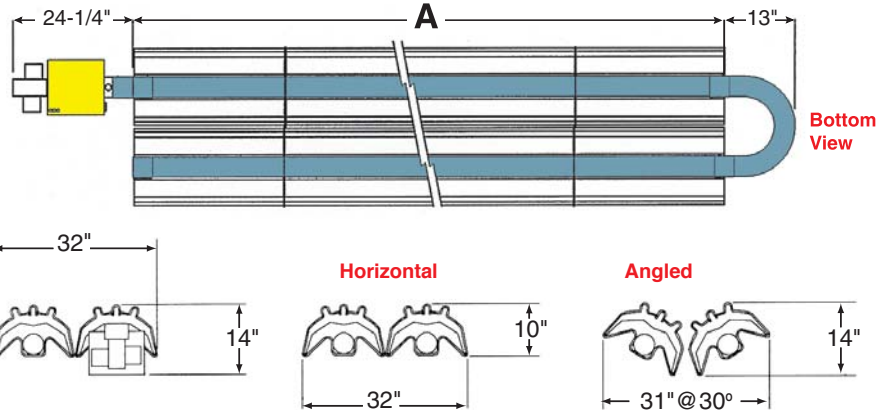

¹5' or 10' lengths as required

System Information

Manifold Operating Pressure

Natural Gas & LP/Propane: 3.5" WC

Minimum Inlet Pressure

Natural Gas: 6" WC
 LP/Propane: 11" WC
 1/2" FPT Gas Inlet

Electrical Rating: 120VAC-60Hz-1 Phase

Warranty

2 year limited warranty on all controls
 5 year limited warranty on all tubing
 10 year limited warranty on burner core

Safety

The SunSpan Residential Garage Heater will provide safe, reliable comfort heating when operated in accordance with the manufacturer's printed instructions for installation, operation and cleaning. For your safety, installation and service must be performed by a licensed contractor and conform to local codes. Also, adequate ventilation must always be provided according to codes. Do not store gasoline or other combustibles in the vicinity of the heater. Keep children, draperies and garments away from the heater. Do not touch the heater or tubes during operation.

Clearances to Combustibles

FOR ALL HEATERS		Top, Front and Rear are measured from reflector. Below is measured from bottom of tube.																									
TOP OF REFLECTOR		REFLECTOR WIDTH = 15.75 IN.																									
12 inches																											
END OF BURNER		FOR 0° TO 30° ANGLE																									
12 inches		<table border="1"> <thead> <tr> <th>SERIES</th> <th>MBTUH</th> <th>FRONT</th> <th>REAR</th> <th>BELOW</th> </tr> </thead> <tbody> <tr> <td rowspan="2">SRH</td> <td>40</td> <td rowspan="2">24"</td> <td rowspan="2">24"</td> <td>40"</td> </tr> <tr> <td>45</td> </tr> <tr> <td rowspan="2">SRH</td> <td>50</td> <td rowspan="2">24"</td> <td rowspan="2">24"</td> <td>50"</td> </tr> <tr> <td>55</td> </tr> <tr> <td rowspan="2">SRH</td> <td>60</td> <td rowspan="2">24"</td> <td rowspan="2">24"</td> <td>50"</td> </tr> <tr> <td>60</td> </tr> </tbody> </table>			SERIES	MBTUH	FRONT	REAR	BELOW	SRH	40	24"	24"	40"	45	SRH	50	24"	24"	50"	55	SRH	60	24"	24"	50"	60
SERIES	MBTUH	FRONT	REAR	BELOW																							
SRH	40	24"	24"	40"																							
	45																										
SRH	50	24"	24"	50"																							
	55																										
SRH	60	24"	24"	50"																							
	60																										
END OF U-BEND																											
50 inches																											
Minimum mounting height: Bottom of tube to floor: 8 ft. U.S.A.; 7 ft. Canada																											



GAS INFRARED HEATERS

P.O. Box 80217, Rochester, MI 48308
 Phone: 866-664-3824 • Fax: 248-651-0357
 E-Mail: sales@sunspanheaters.com
 Web: sunspanheaters.com