



Form DF-IOM-2
800080

TWO-STAGE TUBE HEATERS DF

TWO-STAGE GAS-FIRED LOW-INTENSITY INFRA-RED TUBE HEATERS

FOR EITHER INDOOR OR OUTDOOR INSTALLATION

INSTALLATION, OPERATION, & MAINTENANCE INSTRUCTIONS



DFS
(STRAIGHT TUBE)



DFU
(U-TUBE)

! WARNING !

Improper installation, adjustment, alteration, service or maintenance can cause property damage, injury or death. Read the installation, operating, and maintenance instructions thoroughly before installing or servicing this equipment.

FOR YOUR SAFETY

- If you smell gas: open windows; don't touch electrical switches, extinguish any open flames; evacuate the structure; call your gas supplier immediately.

WARNING – NOT FOR RESIDENTIAL USE

- Failure to comply with instructions could result in unsafe operation, property damage, personal injury, and/or death. A gas-fired appliance could expose you to substances in fuel or from fuel combustion, which have been determined by the State of California to cause cancer, birth defects or other reproductive harm. For industrial or commercial use only.
- Retain these instructions for future reference. Contact factory for further information.

WARNINGS

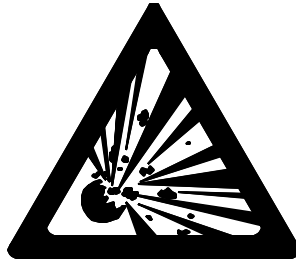
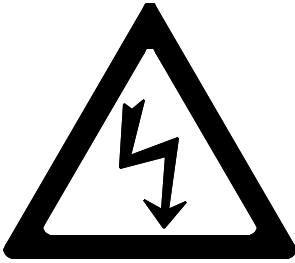

- Protect yourself and others by observing all safety information.

| WARNING | CAUTION |
|--|---|
| <p style="text-align: center;">FIRE OR EXPLOSION HAZARD</p> <p><i>Can cause property damage, severe injury or death.</i></p> <ul style="list-style-type: none"> • Read manual carefully before installing, or servicing this equipment, or serious injury or death may result. • Check minimum clearance to combustibles to make certain that heater is in a safe location. Combustible items located too close to the heater could cause a serious fire hazard. In storage areas, signs for maximum permissible stacking height to maintain clearance from the heater to combustible materials must be posted adjacent to the heater thermostats or in the absence of such thermostats in a conspicuous location. • Operating the heater in an atmosphere containing combustible dust or flammable vapors is dangerous and may potentially result in injury or death. • Heaters must be oriented in such a way as to maintain minimum clearances to vehicles parked underneath them. • This heater expands and contracts with each cycle. The installation of the gas connection and mounting hardware must accommodate this movement; otherwise, a fire or explosion hazard may occur. • This heater is equipped with an automatic ignition and does not contain a pilot. DO NOT attempt to light the burner manually, this could result in serious personal injury or fire hazard. | <p style="text-align: center;">MECHANICAL HAZARD</p> <ul style="list-style-type: none"> • DO NOT use high pressure to test the gas pipes with the burner still attached. This will cause damage to the controls within the burner requiring them to be replaced. • If heater is being operated in an atmosphere with a negative pressure or an atmosphere containing contaminants, an outside combustion air supply is required. Failure to provide outside combustion air may allow excessive heat to back up to the blower wheel and bearings severely shortening service life. • Correct inlet pressure is important to efficiency and long lasting operation of the burner. • The burner, tubing, and accessories expand and contract with each cycle. The system must be installed so that the mounting hardware and gas line will accommodate these changes. • All models of low-intensity heaters include a turbulator, which must be located in the last ten (10) feet (3.0 m) of the burner tube [exception: 15-foot (4.6 m) units have the turbulator in the first 10 feet (3.0 m).] • Before servicing the burner or removing the cover panel, all electrical and gas supplies must be disconnected. • Give consideration to construction such as partitions, storage racks, hoists, etc., and their relation to the installation of the heater. • The heater must be installed and serviced ONLY by trained gas installation and service personnel. |

IMPORTANT

- Failure to follow these instructions may result in injury or property damage.
 - Low-intensity heaters **cannot** be used in the following environments: explosion-proof, or residential living/sleeping quarters.
 - Low-intensity heaters **may or may not** be used in the following environments: enclosed swimming pool, process heating, or contaminated atmosphere applications.
- NOTE: Contact factory if in any doubt.**

TABLE OF CONTENTS

This instruction manual may not cover all details or variations in this equipment, or cover every possible situation to be met in connection with installation, operation, or maintenance. Should problems arise that are not covered sufficiently in these instructions, the purchaser is advised to contact the engineering department for further information.

| SECTION TITLES – summary of information included | PAGE(S) |
|---|---------|
| WARNINGS – precautions and important safety information | 2 |
| TABLE OF CONTENTS | 3 |
| INSTALLATION CODES – applicable codes and warnings; gas conversions | 4 |
| CANADIAN ADDENDUM – applicable codes and variances from this manual | 5 |
| CLEARANCE TO COMBUSTIBLES – minimum distances from heater to combustible objects | 6 |
| MOUNTING CONSIDERATIONS – minimum heater mounting heights, distances, angles and spacing; high altitude considerations | 7 |
| OVERVIEW DRAWINGS – overview of venting, suspension, location, and typical installation | 8-9 |
| HEATER CONFIGURATIONS – possible arrangements of heat exchangers; reflector options | 10 |
| BASIC SYSTEM CONFIGURATIONS – straight and U-tube configurations with component identification | 11 |
| COMBUSTION CHAMBERS – components and specifications of combustion chambers | 12 |
| HEAT EXCHANGERS – components and specifications of middle and exhaust end heat exchangers | 13 |
| COMBUSTION AIR SUPPLY – application, construction, dimensions, and illustrations | 14 |
| EXHAUST VENTING – application, construction, dimensions, and illustrations | 15 |
| WINDY CONDITION NOTES – methods for suspension and notes | 16 |
| U-TUBE INSTALLATION – suspension and orientation of U-tube heaters | 17 |
| INSTALLATION – preparation and installation | 18-19 |
| ELECTRICAL SUPPLY AND THERMOSTATIC CONTROL – electrical ratings, schematics, 24 and 120 VAC thermostat arrangements, illustrations | 20-21 |
| THERMOSTAT WIRING WHEN BLOWER ENCLOSED – field wiring for 24-volt thermostat for 2-stage burner with blower enclosure | 22 |
| GAS VALVE – top view, features identification key, and isometric view | 23 |
| GAS SUPPLY AND GAS PRESSURE – gas piping, inlet and manifold pressures | 24 |
| STARTUP – procedures | 25 |
| MAINTENANCE – basic procedures | 26 |
| TROUBLESHOOTING – symptoms with light flashes, possible causes and corrective actions | 27 |
| REPLACEMENT PARTS – exploded view and part descriptions | 28 |

All rights reserved. No part of this work covered by the copyrights herein may be reproduced or copied by any means: graphic, electronic or mechanical, including photocopying, recording, taping, information storage and retrieval systems without written permission.

INSTALLATION CODES

ATTENTION

Mount a copy of these instructions adjacent to heater and retain a copy for future reference.

A limited number of excerpts from various standards are outlined in the following instructions. However, the installer must be familiar with all of the various requirements and is responsible for compliance with the applicable codes.

Gas-fired low-intensity infrared heaters are C.S.A. International Design Certified for either indoor or outdoor installation. If you have any questions call factory before attempting any installation work.

Gas-fired low-intensity infrared heaters are designed and manufactured in compliance with American National Standards Institute standard ANSI Z83.20-latest edition. Gas-fired low-intensity infrared heaters must be installed in accordance with applicable codes and only by a qualified agency. In the absence of local codes, installation must be in accordance with the National Fuel Gas Code ANSI Z223.1 / NFPA 54-latest edition. All electrical work must conform to the National Electrical Code ANSI / NFPA 70 - latest edition. The installation must meet the requirements of the Occupational Safety and Health Act (OSHA) which requires OSHA approved service and safety access to the systems after they are installed.

GENERAL

All installations must be in accordance with ANSI Z223.1 / NFPA 54 - latest edition) National Fuel Gas Code especially:

SECTION 9.18 covers the general provisions for installing infrared heaters. Note the requirements for posting signs to specify the maximum permissible stacking height to maintain required clearances from heater to combustibles (9.18.2). Note also the exhaust requirement of 4 CFM/1000 BTUH (.38 m³/minute/kW) when operating in the unvented mode (9.18.3.1). (See Canadian Addendum section herein.)

Exhaust openings for removing the flue products shall be above the level of the heater (9.18.3.2).

SECTION 8.1.11.1 states that in commercial garages "Gas utilization equipment installed in enclosed, basement, or underground parking structures shall be installed in accordance with NFPA 88A, Standard for Parking Structures."

SECTION 8.2 Accessibility and Clearance.

SECTION 8.3 Air for Combustion and Ventilation.

AIRCRAFT HANGARS

In aircraft hangars, the heaters must be installed in accordance with ANSI / NFPA 409-latest edition, chapter 5.

SECTION 5-4.5.2 specifies a clearance of ten (10) feet (3.05 m) to the bottom of the heater from the highest surface of the wings or engine enclosures of the highest aircraft which may be housed in the hangar.

SECTION 5-4.5.3 specifies a minimum clearance of eight (8) feet (2.44 m) from the floor to the heater in other sections of aircraft hangars such as offices or shops which may communicate with areas used for servicing and storage.

SECTION 5-4.5.4 specifies the heaters must be located so as to be protected from damage by aircraft or other objects such as cranes and moveable scaffolding. In addition, the heaters must be located so as to be accessible for servicing, adjustment, etc.

PUBLIC GARAGES

In public garages, the heaters must be installed in accordance with National Fire Protection Association code NFPA 88B-latest edition, Section 3-2.3.

SECTION 3-2.3.1 states that overhead heaters may be used provided they are "located not less than eight (8) ft (2.4 m) above the floor and installed in accordance with the conditions of their approval." (**WARNING:** Minimum clearances indicated on the heater's serial plate must be maintained for vehicles parked below the heater.)

SECTION 3-2.3.2 states that "a distance shall be maintained between the heater and its vent and any adjacent combustible material (which is part of the building or its contents) in conformance with NFPA 54, National Fuel Gas Code".

PARKING STRUCTURES

Approval requirements for parking structures are contained in NFPA 88A-latest edition and described in Section 4-2.

MATERIAL SAFETY DATA SHEETS (MSDS)

Gas-fired low-intensity infrared heaters comply with the US Superfund Amendments and Reauthorization ACT (SARA) Title III. No Material Safety Data Sheets are required.

UL LISTING

Gas-fired low-intensity infrared heaters are design certified by C.S.A. International for compliance with the current American National Standard Z83.20. C.S.A. International is the appropriate agency as they specialize in gas appliances while Underwriters Laboratories (UL) specialize in electric appliances.

If, however, UL were to design certify our heaters, it would be to the same American National Standard Z83.20. Certification by UL is not required, as it would be redundant.

LOCAL APPROVALS

Gas-fired low-intensity infra-red heaters have been granted local approvals by such governing bodies as New York City (A Series: MEA 232-95-E Vol. 2; B and C Series MEA 417-86-E Vol. 5; MB Series MEA 233-95-E Vol. 2; MC Series 233-95-E Vol. 2); City of Minneapolis, Minnesota (#05444); the Commonwealth of Massachusetts; and the State of Nebraska.

GAS/RATING CONVERSION OF INSTALLED HEATER

Conversions of gas type and BTUH ratings are possible. Consult factory for proper instructions. Identify the model and serial numbers from the serial plate located on the exterior of the burner housing. Note the radiant tube length. Review the systems listed in the BASIC SYSTEM CONFIGURATIONS section of these instructions to determine whether the installed heater can be converted as desired.

CANADIAN ADDENDUM

NOTES TO INSTALLER

Gas-fired low-intensity infrared heaters are C.S.A. International design certified for indoor installation only. They are designed and manufactured in compliance with *CSA Standard for Gas-Fired Low-Intensity Infrared Heaters*, CSA 2.34-2001.

The installation must conform with local building codes or, in the absence of local codes, with the current Canadian *Natural Gas and Propane Installation Code*, CSA B149.1.

The electrical connection shall comply with the local codes or, in the absence of local codes, with the current *Canadian Electrical Code*, CAN/CSA C22.1, Part I and Part II, and *Electrical Features of Fuel Burning Equipment*, CAN/CSA C22.2 No. 3.

UNVENTED HEATERS

The exhaust venting requirement is 3 CFM per 1,000 BTUH (.29 m³ per minute per kW) for natural gas and 4 CFM per 1,000 BTUH (.38 m³ per minute per kW) for propane gas.

AIRCRAFT HANGARS

Gas-fired low-intensity infrared heaters are suitable for use when installed in accordance with the current Canadian *Natural Gas and Propane Installation Code*, CSA B149.1.

COMBUSTION AIR AND EXHAUST VENTING

Vent terminal clearances shall be in accordance with the current Canadian *Natural Gas and Propane Installation Code*, CSA B149.1.

A horizontal vent shall not terminate less than 6 feet (1.83 m) from a combustion air inlet or another appliance, 3 feet (.91 m) from any other building opening or any gas service regulator, or 7 feet (2.13 m) above grade and shall not terminate directly above a gas utility meter or gas service regulator.

MANUAL SHUT-OFF VALVES

From the current Canadian *Natural Gas and Propane Installation Code*, CSA B149.1.

A manual shut-off valve shall be of the plug, ball, or eccentric type and it shall not be subjected to either a temperature or a pressure greater than its certified rating.

A readily accessible manual shut-off valve shall be installed to control the supply of gas to each appliance and the valve shall be located, in either the drop or riser, as close as possible to the valve train of a commercial and industrial type appliance.

CLEARANCE TO COMBUSTIBLES*

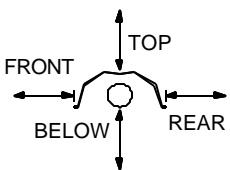
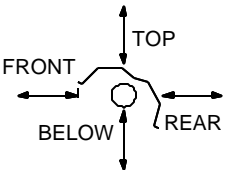
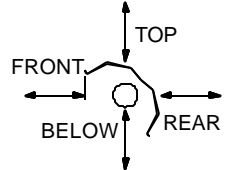
| | |
|--|--|
| <p style="text-align: center;">CLEARANCES APPLICABLE FOR ALL HEATERS* Inches (Centimeters)</p> <p style="text-align: center;"><u>TOP OF REFLECTOR</u> 12 (31)</p> <p style="text-align: center;"><u>END OF BURNER</u> 12 (31)</p> <p style="text-align: center;"><u>END OF U-BEND</u> 68 (173)</p> | <p style="text-align: center;">Top, Front, and Rear clearances are measured from reflector. Below clearance is measured from bottom of tube. Clearance to combustibles* measurements are given in inches and (centimeters).</p> <div style="display: flex; justify-content: space-around; text-align: center;"> <div style="width: 30%;"> <p>0° MOUNTING</p>  </div> <div style="width: 30%;"> <p>1°-30° MOUNTING</p>  </div> <div style="width: 30%;"> <p>31°-45° MOUNTING</p>  </div> </div> <p style="text-align: center;">REFLECTOR WIDTH = 15.75" (40cm)</p> |
|--|--|

| Input | 0° to 30° Reflector Angle | | | 31° to 45° Reflector Angle | | |
|-----------------------------|---------------------------|----------|-----------|----------------------------|---------|-----------|
| MBTUH (kW) | FRONT | REAR | BELOW | FRONT | REAR | BELOW |
| 85 / 65 (25 / 19) | 24 (61) | 24 (61) | 60 (152) | N/A | N/A | N/A |
| 100 / 65 (29 / 19) | 24 (61) | 24 (61) | 60 (152) | N/A | N/A | N/A |
| 125 / 95 (37 / 28) | 32 (82) | 32 (82) | 72 (183) | N/A | N/A | N/A |
| 150 / 100 (44 / 29) | 48 (122) | 48 (122) | 82 (209) | 70 (189) | 12 (31) | 82 (209) |
| 175 / 125 (51 / 37) | 58 (148) | 58 (148) | 92 (234) | 80 (203) | 12 (31) | 92 (234) |
| 200 / 145 (59 / 42) | 68 (173) | 68 (173) | 102 (259) | 90 (229) | 12 (31) | 102 (259) |

***MINIMUM CLEARANCES** specified in these tables must be maintained to combustible and other materials, which may be damaged by temperatures 90°F above (50°C above) ambient room temperature. Minimum clearances to combustibles are also specified on each heater's serial plate. According to the National Fuel Gas Code (NFPA 54), "in locations used for the storage of combustible materials, signs must be posted to specify the maximum permissible stacking height to maintain required clearances from the heater to the combustibles." Gas supply lines, electrical supply lines, or sprinkler heads shall not be located within the minimum clearances to combustibles indicated above.

NOTE: Carefully examine any surrounding materials near the heater. Materials such as plastic have low service temperature ratings and can be discolored or damaged by heat.

MOUNTING CONSIDERATIONS

- **CLEARANCE TO COMBUSTIBLES MUST BE MAINTAINED.**
- Mounting heights lower than the recommended **Minimum Height** may be used if personnel are not kept directly under heater.
- The **Distance From Wall** measurement provides the most effective heat dispersion balance between the floors and walls.
- There is practically no limitation on a maximum mounting height.
- By design, a straight infrared heater will produce more heat at the burner end than at the exhaust end. Locate the burner end where more heat is desired.

| Reflector | Standard Reflector | | | | Parabolic Reflector | | | | Standard & Parabolic Reflector |
|--------------------------------|-----------------------------|-------------|---------------------------------|------------|-----------------------------|-------------|---------------------------------|------------|--|
| | Horizontal | 30° - 45° | Horizontal | 30° - 45° | Horizontal | 30° - 45° | Horizontal | 30° - 45° | |
| Mounting Angle | Minimum Height ft (m) | | Distance From Wall ft (m) | | Minimum Height ft (m) | | Distance From Wall ft (m) | | Max. Distance Between Rows ft (m) |
| 85 / 65 (25 / 19) | 11 (3.4) | 9 (2.7) | 8 (2.4) | 1 (0.3) | 14 (4.3) | 12 (3.7) | 6 (1.8) | 1 (0.3) | 90 (27.4) |
| 100 / 65 (29 / 19) | 12 (3.7) | 10 (3.0) | 8 (2.4) | 1 (0.3) | 15 (4.6) | 13 (4.0) | 6 (1.8) | 1 (0.3) | 95 (29.0) |
| 125 / 95 (37 / 28) | 14 (4.3) | 12 (3.7) | 12 (3.7) | 1 (0.3) | 16 (4.9) | 14 (4.3) | 9 (2.7) | 1 (0.3) | 105 (32.0) |
| 150 / 100 (44 / 29) | 16 (4.9) | 14 (4.3) | 12 (3.7) | 1 (0.3) | 18 (5.5) | 16 (4.9) | 9 (2.7) | 1 (0.3) | 105 (32.0) |
| 175 / 125 (51 / 37) | 17 (5.2) | 15 (4.6) | 14 (4.3) | 1 (0.3) | 19 (5.8) | 17 (5.2) | 11 (3.4) | 1 (0.3) | 110 (33.5) |
| 200 / 145 (59 / 42) | 19 (5.8) | 17 (5.2) | 15 (4.6) | 1 (0.3) | 20 (6.1) | 18 (5.5) | 12 (3.7) | 1 (0.3) | 115 (35.1) |

HIGH ALTITUDE

If a heater is to be installed at a high altitude, in excess of two thousand feet (610 m) above sea level, consult the factory (U.S. & CANADA).

OVERVIEW DRAWINGS (1 OF 2)

WHEN GAS PRESSURE EXCEEDS 14" (35 CM) W.C. A FIRST STAGE REGULATOR MUST BE INSTALLED

LOCAL CODES MAY REQUIRE AN ADDITIONAL SHUT-OFF COCK BE INSTALLED IN THE GAS LINE AHEAD OF THE DRIP LEG

VENT CAP MUST BE 6" (15 CM) HIGHER THAN SNOW DEPTH

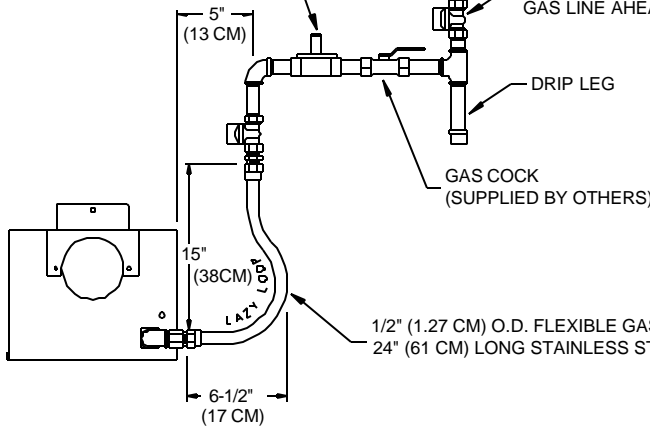

"B" VENT PIPE ADAPTOR
ROOF FLASHING (NOT SUPPLIED)

GAS CONNECTION DIAGRAM

ALL HANGING CHAINS MUST BE PLUMB AND VERTICAL IN ALL DIRECTIONS WHEN INITIALLY INSTALLED

USE A SAFETY CHAIN WITH ENOUGH SLACK AS INDICATED. SAFETY CHAIN [MUST BE 1/0 TENSO AND HAVE A MINIMUM WORKING LOAD RATING OF 200 LBS. (90.7 KG)] AND S-HOOK [1/4" (.64 CM) STEEL WIRE DIA., 3/4" (1.91 CM) INSIDE HOOK DIA., 350 LB. PULL TEST] TO BE PROVIDED BY OTHERS.

4" (10.2 CM) VENT PIPE ADAPTOR (STANDARD FACTORY ACCESSORY)

HANGER REQUIRED AT TUBE CLAMP TO SUPPORT BURNER (NOT TO SUPPORT REFLECTOR HERE)

INLET AIR CAP MUST BE 6" (15 CM) HIGHER THAN SNOW DEPTH

ROOF FLASHING (NOT SUPPLIED)

DISTANCE FROM SUSPENSION POINT TO TOP OF COVER PLUS 6" (15 CM) = LENGTH OF SAFETY CHAIN

BURNER
12" (30 CM) MIN. CLEARANCE

INLET AIR SLEEVE (SEAM TO BE AT TOP)

4" (10.2 CM) I.D. FLEX DUCT - 18" (46 CM) LONG WITH (2) TWO HOSE CLAMPS

SUPPLY PIPING MUST NOT EXCEED 20 LINEAR FEET (6 M) AND ONE 90° ELBOW.

4" B-VENT ADAPTOR (PROVIDED BY OTHERS)

23" (74 CM)
17" (43 CM)
12" (31 CM)
4" (1.2m) MIN. 8 (2.4m) MAX.
4" (1.2m) MIN. 8 (2.4m) MAX.

COMBUSTION CHAMBER 4" (10.2 CM) O.D. X 10'-0" (3.048 M) LONG

ADDITIONAL COMBUSTION AIR SUPPLY (NOT SUPPLIED) SINGLE WALL 26 GAUGE (.044 CM) MINIMUM GALVANIZED SHEET METAL PIPE OR SCHEDULE 40 PVC (SEAM MUST BE AT TOP)

HEAT EXCHANGER 4" (10.2 CM) O.D. X 5'-0" (1.524 M) OR X 10'-0" (3.048 M) LONG

4" (10.2 CM) VENT PIPE ADAPTOR

INLET AIR CAP (OPTIONAL ACCESSORY)

INLET AIR BOX (ALTERNATE OPTIONAL ACCESSORY) USE APPROPRIATE FASTENERS (NOT SUPPLIED)

OVERVIEW DRAWINGS (2 OF 2)

MAINTAIN 18 INCH (46 CM) MINIMUM CLEARANCE TO COMBUSTIBLES FOR ENTIRE LENGTH OF PIPING

FOR ALL INDOOR JOINTS, USE RTV SEALANT TO PREVENT HOT FLUE GAS LEAKAGE INTO THE BUILDING (USE A SHEET METAL PIPE AND CRIMPER FOR JOINING IDENTICAL SIZE SHEET METAL PIPES) USE THREE (3) #6 SHEET METAL SCREWS (SMS) PER VENT PIPE JOINT. THE VENT PIPE SEAM SHOULD BE ON TOP WITH ONE SMS ON TOP AND ONE SMS 120 DEGREES FROM THE TOP ON EACH SIDE.

ADDITIONAL EXHAUST VENT PIPING (NOT SUPPLIED) 4" (10.2 CM) I.D. SINGLE WALL 26 GAUGE (.044 CM) MINIMUM GALVANIZED SHEET METAL PIPE (SEAM TO BE AT TOP) (OR OTHER FACTORY-APPROVED MATERIALS). VENT PIPING MUST NOT EXCEED 20 LINEAR FEET (6 M) AND ONE 90° ELBOW.

ADD NON-COMBUSTIBLE SUPPORT (NOT SUPPLIED) EVERY 5 OR 6 FEET (1.5 OR 1.8 M) APART AND ADEQUATE FOR THE PIPING WEIGHT

FOR COMBUSTIBLE WALLS ONLY USE A 2" (5.1 CM) CLEARANCE NON-COMBUSTIBLE VENTILATING METAL THIMBLE (NOT SUPPLIED). FOR NON-COMBUSTIBLE WALLS ONLY 4.250" (10.8 CM) DIA. HOLE FOR 4" (10.2 CM) O.D. PIPE ADD NON-COMBUSTIBLE PROTECTION AROUND THE HOLE IF NECESSARY.

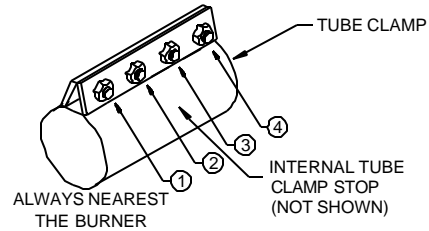
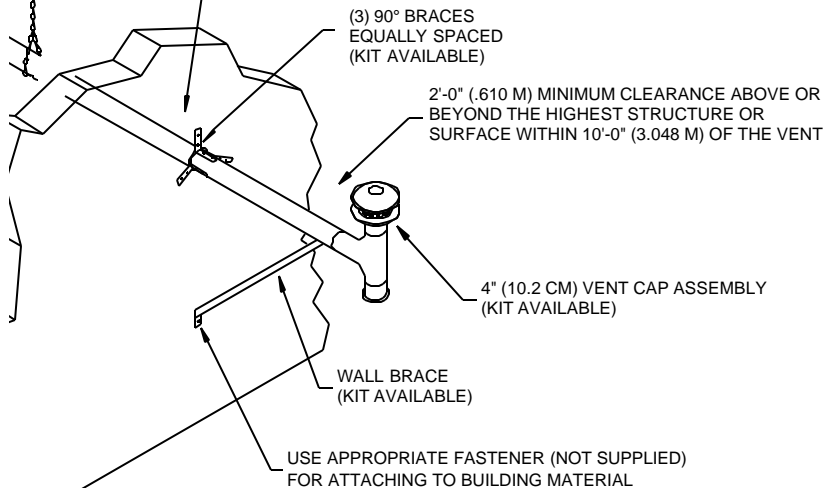

TIGHTEN NUTS A HALF TURN AT A TIME, IN A 2,3,4,1 SEQUENCE UNTIL THE FLANGES OF THE CLAMP TOUCH AND 65 FT-LBS (88 NM) IS ACHIEVED AT EACH NUT TO ASSURE PROPER SEATING OF THE CLAMPS INNER SLEEVE.

TUBE CLAMP

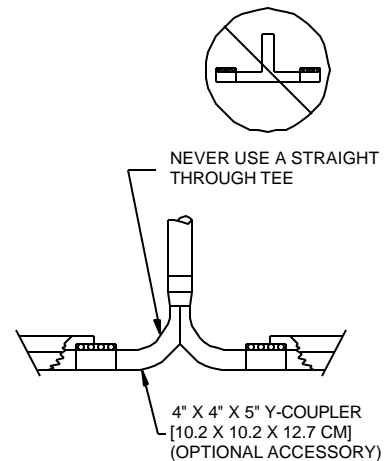

OPTIONAL COMMON VENTING THROUGH ROOF OR WALL

BOTH HEATERS MUST BE CONTROLLED BY A SINGLE THERMOSTAT

CAUTION

- The first twenty (20) feet (6.1 m) of radiant tube extending from the burner MUST be installed straight.
- There is one exception. A U-Tube heater may have a 180 degree U-bend interposed AFTER the first ten (10) feet (3.0 m).
- Electrical wiring diagrams can be found in the ELECTRICAL SUPPLY AND THERMOSTATIC CONTROL section.

HEATER CONFIGURATIONS

Low-intensity heaters can be arranged in many configurations; some common ones are illustrated below. It is important to limit the number of bends since each bend slows the movement of air inside the tube, resulting in decreased efficiency.

1. The **first twenty feet** (6.1 m) of radiant tube extending from the burner must be installed **straight** [**EXCEPTION:** a 15 foot (4.6 m) or 20 foot (6.1 m) heater may have a 180° U-bend interposed after the first 10 feet (3.0 m)].
2. Each system can use a maximum of **two (2)** 16 gauge (.17 cm) aluminized steel 45° elbows, **OR two (2)** 16 gauge (.17 cm) aluminized steel 90° elbows, **OR one (1)** 16 gauge (.17 cm) aluminized steel 180° U-bend. Elbows and U-bends can not be used **simultaneously** in the same system.
3. All tube sections of a unit must be mounted on the same horizontal plane. For exceptions or other configurations, consult factory.
4. Special reflectors are available: 90° elbow reflector, 180° U-bend reflector, side extension reflector and inverted V-deflectors. Contact factory for more information.
5. Use factory accessory elbows and U-bends only.

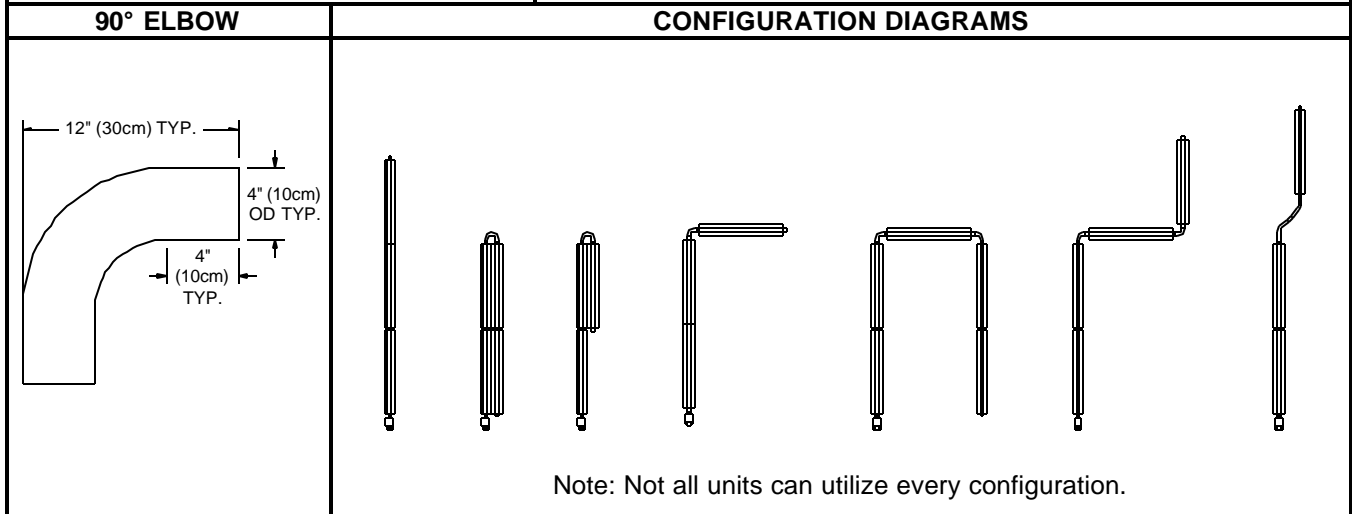
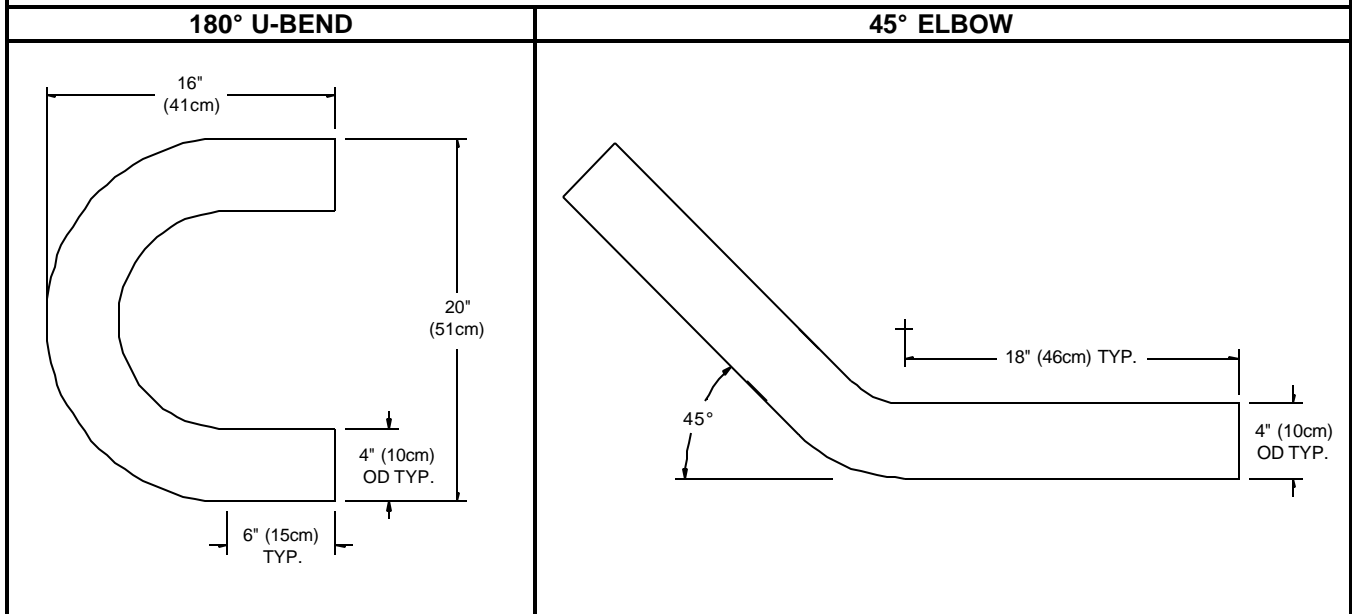

BASIC SYSTEM CONFIGURATIONS

NOTE: These are the recommended configurations for your heater. Contact the factory with any questions.
 LEGEND: L : LP/Propane gas, N : Natural gas, ▶ : Burner, U : 180° U-Bend.

| STRAIGHT TUBE | | | HEATER COMPONENTS | | | |
|---------------------------|------------------|-------------|--------------------------|-----------------------|---------------------|----------------|
| Burner Size MBTUH (kW) | Length ft (m) | Gas Type | ▶ | Combustion Chamber | Heat Exchangers | Exhaust End |
| 85 / 65 (25 / 19) | 20 (6) | N /(L) | ▶ | C2 | | H9 (H1) |
| 85 / 65 (25 / 19) | 25 (8) | N /(L) | ▶ | C2 | H6 | H9 (H1) |
| 100 / 65 (29 / 19) | 30 (9) | N / L | ▶ | C2 | H2 | H5 |
| 125 / 95 (37 / 28) | 30 (9) | N - only | ▶ | C4 | H2 | H1 |
| 100 / 65 (29 / 19) | 35 (11) | N / L | ▶ | C2 | H2 H6 | H5 |
| 125 / 95 (37 / 28) | 35 (11) | N - only | ▶ | C4 | H2 H6 | H1 |
| 100 / 65 (29 / 19) | 40 (12) | N / L | ▶ | C2 | H2 H2 | H5 |
| 125 / 95 (37 / 28) | 40 (12) | N /(L) | ▶ | C4 | H2 H2 | H5 |
| 150 / 100 (44 / 29) | 40 (12) | N / L | ▶ | C4 | H2 H2 | H5 |
| 125 / 95 (37 / 28) | 45 (14) | N /(L) | ▶ | C4 | H2 H2 H6 | H5 |
| 150 / 100 (44 / 29) | 45 (14) | N / L | ▶ | C4 | H2 H2 H6 | H5 |
| 125 / 95 (37 / 28) | 50 (15) | N /(L) | ▶ | C4 | H2 H2 H2 | H5 |
| 150 / 100 (44 / 29) | 50 (15) | N / L | ▶ | C4 | H2 H2 H2 | H5 |
| 175 / 125 (51 / 37) | 50 (15) | N / L | ▶ | C4 | H2 H2 H2 | H5 |
| 200 / 145 (59 / 42) | 50 (15) | N / L | ▶ | C4 | H2 H2 H2 | H5 |
| 150 / 100 (44 / 29) | 55 (17) | N / L | ▶ | C4 | H2 H2 H2 H6 | H5 |
| 175 / 125 (51 / 37) | 55 (17) | N / L | ▶ | C4 | H2 H2 H2 H6 | H5 |
| 200 / 145 (59 / 42) | 55 (17) | N / L | ▶ | C4 | H2 H2 H2 H6 | H5 |
| 150 / 100 (44 / 29) | 60 (18) | N / L | ▶ | C4 | H2 H2 H2 H2 | H5 |
| 175 / 125 (51 / 37) | 60 (18) | N / L | ▶ | C4 | H2 H2 H2 H2 | H5 |
| 200 / 145 (59 / 42) | 60 (18) | N / L | ▶ | C4 | H2 H2 H2 H2 | H5 |
| 175 / 125 (51 / 37) | 65 (20) | N / L | ▶ | C4 | H2 H2 H2 H2 H6 | H5 |
| 200 / 145 (59 / 42) | 65 (20) | N / L | ▶ | C4 | H2 H2 H2 H2 H6 | H5 |
| 175 / 125 (51 / 37) | 70 (21) | N / L | ▶ | C4 | H2 H2 H2 H2 H2 | H5 |
| 200 / 145 (59 / 42) | 70 (21) | N / L | ▶ | C4 | H2 H2 H2 H2 H2 | H5 |
| U-TUBE | | | HEATER COMPONENTS | | | |
| Burner Size MBTUH (kW) | Length ft (m) | Gas Type | ▶ | Combustion Chamber | Heat Exchangers | Exhaust End |
| 85 / 65 (25 / 19) | 20 (6) | N /(L) | ▶ | C2 | U | H9 (H1) |
| 100 / 65 (29 / 19) | 30 (9) | N / L | ▶ | C2 | H6 U H6 | H5 |
| 125 / 95 (37 / 28) | 30 (9) | N - only | ▶ | C4 | H6 U H6 | H1 |
| 100 / 65 (29 / 19) | 40 (12) | N / L | ▶ | C2 | H2 U H2 | H5 |
| 125 / 95 (37 / 28) | 40 (12) | N /(L) | ▶ | C4 | H2 U H2 | H5 |
| 150 / 100 (44 / 29) | 40 (12) | N / L | ▶ | C4 | H2 U H2 | H5 |
| 125 / 95 (37 / 28) | 50 (15) | N /(L) | ▶ | C4 | H2 H6 U H6 H2 | H5 |
| 150 / 100 (44 / 29) | 50 (15) | N / L | ▶ | C4 | H2 H6 U H6 H2 | H5 |
| 175 / 125 (51 / 37) | 50 (15) | N / L | ▶ | C4 | H2 H6 U H6 H2 | H5 |
| 200 / 145 (59 / 42) | 50 (15) | N / L | ▶ | C4 | H2 H6 U H6 H2 | H5 |
| 150 / 100 (44 / 29) | 60 (18) | N / L | ▶ | C4 | H2 H2 U H2 H2 | H5 |
| 175 / 125 (51 / 37) | 60 (18) | N / L | ▶ | C4 | H2 H2 U H2 H2 | H5 |
| 200 / 145 (59 / 42) | 60 (18) | N / L | ▶ | C4 | H2 H2 U H2 H2 | H5 |
| 175 / 125 (51 / 37) | 70 (21) | N / L | ▶ | C4 | H2 H2 H6 U H6 H2 H2 | H5 |
| 200 / 145 (59 / 42) | 70 (21) | N / L | ▶ | C4 | H2 H2 H6 U H6 H2 H2 | H5 |

COMBUSTION CHAMBERS

COMBUSTION CHAMBER COMPONENTS

C2

Used with 85 / 65 MBTUH (25 / 19 kW), and 100 / 65 MBTUH (29 / 19 kW) models.

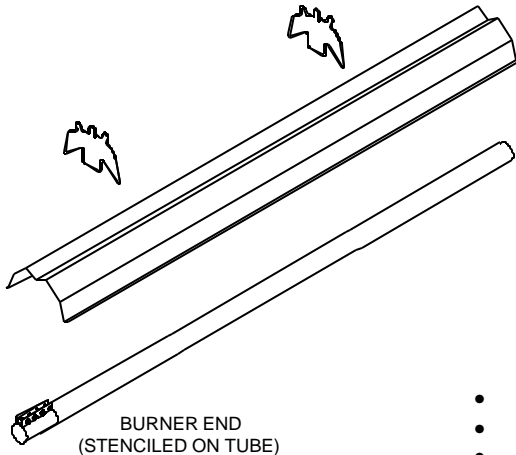

- 10 ft. (3m), 16 ga. (.17cm) aluminized titanium alloy steel tube
- tube clamp
- 10 ft. (3m) aluminum reflector
- (2) tube/reflector hangers

C4

Used with 125 / 95 MBTUH (37 / 28 kW), 150 / 100 MBTUH (44 / 29 kW), 175 / 125 MBTUH (51 / 37 kW), and 200 / 145 MBTUH (59 / 42 kW) models.

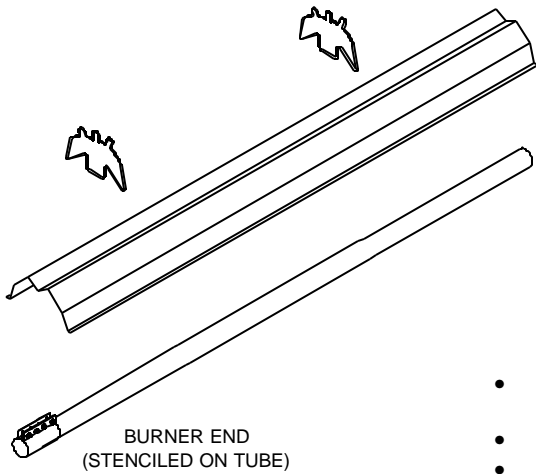

- 10 ft. (3m), 14 ga. (.21cm) aluminized titanium alloy steel tube **painted black**
- tube clamp
- 10 ft. (3m) aluminum reflector
- (2) tube/reflector hangers

10 ft. (3m) reflector [length approx. 119" (302cm)]

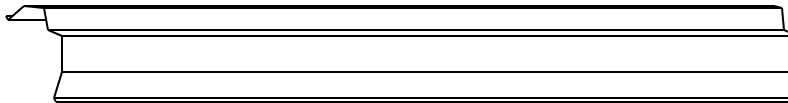

Tube clamp

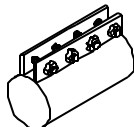

Tube/reflector hanger

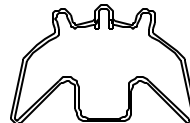

HEAT EXCHANGERS

MIDDLE HEAT EXCHANGER COMPONENTS

H2 10-foot (3m) heat exchanger.

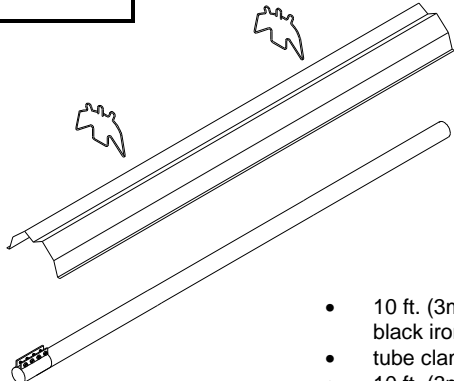

- 10 ft. (3m), 12 ga. (.28cm) black iron steel tube
- tube clamp
- 10 ft. (3m) aluminum reflector
- (2) tube/reflector hangers

H6 5-foot (1.5m) heat exchanger.

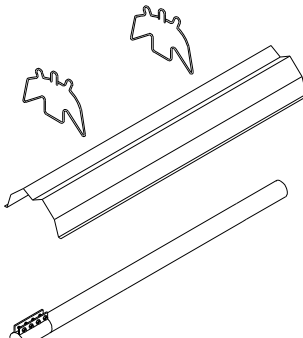

- 5 ft. (1.5m), 12 ga. (.28cm) black iron steel tube
- tube clamp
- 5 ft. (1.5m) aluminum reflector
- (2) tube/reflector hangers

EXHAUST END HEAT EXCHANGER COMPONENTS

H1 Used with 85 / 65 MBTUH (25 / 19 kW) LP / propane gas models and with 125 / 95 MBTUH (37 / 28 kW) natural gas 30 & 35-foot (9 & 11m) models only.

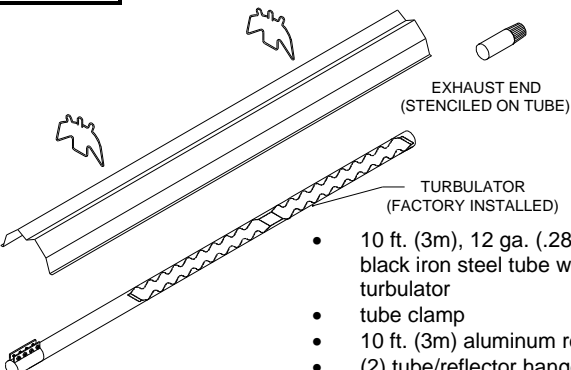

EXHAUST END (STENCILED ON TUBE)

TURBULATOR (FACTORY INSTALLED)

- 10 ft. (3m), 12 ga. (.28cm) black iron steel tube with H1-turbulator
- tube clamp
- 10 ft. (3m) aluminum reflector
- (2) tube/reflector hangers
- vent pipe adaptor

H5 Used with 100 / 65 MBTUH (29 / 19 kW), 125 / 95 MBTUH (37 / 28 kW) LP / propane gas 40 ft (12m) and longer, 150 / 100 MBTUH (44 / 29 kW), 175 / 125 MBTUH (51 / 37 kW), and 200 / 145 MBTUH (59 / 42 kW) models.

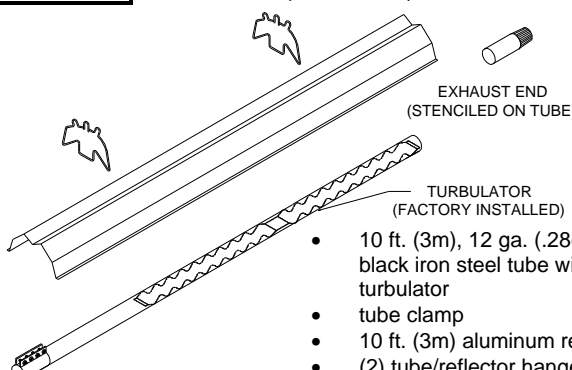

EXHAUST END (STENCILED ON TUBE)

TURBULATOR (FACTORY INSTALLED)

- 10 ft. (3m), 12 ga. (.28cm) black iron steel tube with H5-turbulator
- tube clamp
- 10 ft. (3m) aluminum reflector
- (2) tube/reflector hangers
- vent pipe adaptor

H9 Used with 85 / 65 MBTUH (25 / 19 kW) natural gas models only.

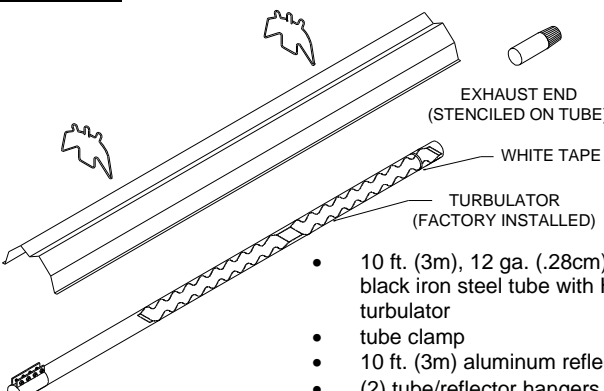

EXHAUST END (STENCILED ON TUBE)

WHITE TAPE

TURBULATOR (FACTORY INSTALLED)

- 10 ft. (3m), 12 ga. (.28cm) black iron steel tube with H9-turbulator
- tube clamp
- 10 ft. (3m) aluminum reflector
- (2) tube/reflector hangers
- vent pipe adaptor

10 ft. (3m) reflector [length approx. 119" (302cm)]

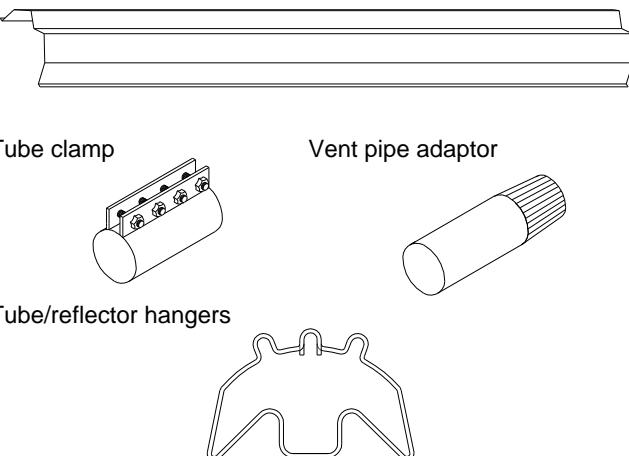

Tube clamp

Vent pipe adaptor

Tube/reflector hangers

COMBUSTION AIR SUPPLY

| GENERAL AIR SUPPLY NOTES | THRU-THE-WALL (OUTDOORS) |
|---|--|
| <ul style="list-style-type: none"> Combustion air supply piping is limited to 20 linear feet (6m) and one 90° elbow for all two-stage models. Atmospheric air for combustion may come from either outdoors or indoors (from within the building). Installation of combustion air supply must comply with the instructions, drawings, and installation notes provided in this section. | |
| OUTDOOR AIR SUPPLY | THRU-THE-ROOF (OUTDOORS) |
| <ul style="list-style-type: none"> In buildings contaminated with excessive dust or dirt, or containing substances which when combined with flame and exhaust products result in corrosive gasses or those under a negative pressure, or high humidity areas, combustion air must come from outdoors. Outdoor air supply may be accomplished by bringing in air through piping from either the roof or wall as the drawings illustrate. When combustion air is supplied from outdoors, the heater must also be vented to the outdoors (EXCEPT high humidity environments consult factory). The roof venting cap used for inlet air cap (roof), inlet air wall cap or inlet air box (wall) must be located at least three (3) feet (.91 m) away from any vent termination and in a manner to prevent blockage by snow. Components supplied by others must be identical to those specified in this manual and be Metalbestos brand, or equal. NO SUBSTITUTIONS. Single wall 4" (10.2 cm) I.D., 26-gauge (.044 cm) minimum stainless or galvanized sheet metal pipe or schedule 40 PVC is recommended for combustion air supply piping. It may be desirable to insulate piping with 1 inch (2.54 cm) of pipe insulation to eliminate condensation from warm inside air. DO NOT use collapsible material for combustion air supply, as it will restrict the proper amount of combustion air from being supplied to the burner. An optional blower enclosure extends the burner housing to enclose the blower. The outdoor air piping is then attached to the enclosure, isolating the outside of the blower and motor from contaminants. | <p>ROOF VENTING CAP USED FOR INLET AIR MUST BE 6 IN. (15 CM) HIGHER THAN SNOW DEPTH.</p> |
| INDOOR AIR SUPPLY | MAXIMUM LENGTH OF AIR SUPPLY PIPE |
| <ul style="list-style-type: none"> When combustion air is to be taken from inside a tightly closed building, an opening must be installed to supply the burner with sufficient air for combustion. For every 4,000 BTUH (1.17 kW) input of the total input of ALL gas-fired equipment, one (1) square inch (6.45 cm²) or more of free area opening must be provided. The openings should be located above the heaters to reduce the effect of drafts. Do not draw combustion air into the heater from an attic space. There is no guarantee adequate air will be supplied. | <ul style="list-style-type: none"> Combustion air supply piping is limited to 20 linear feet (6m) and one 90° elbow for all two-stage models. |

EXHAUST VENTING

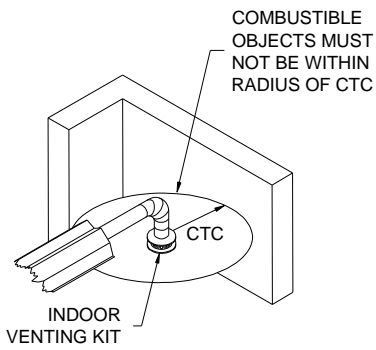
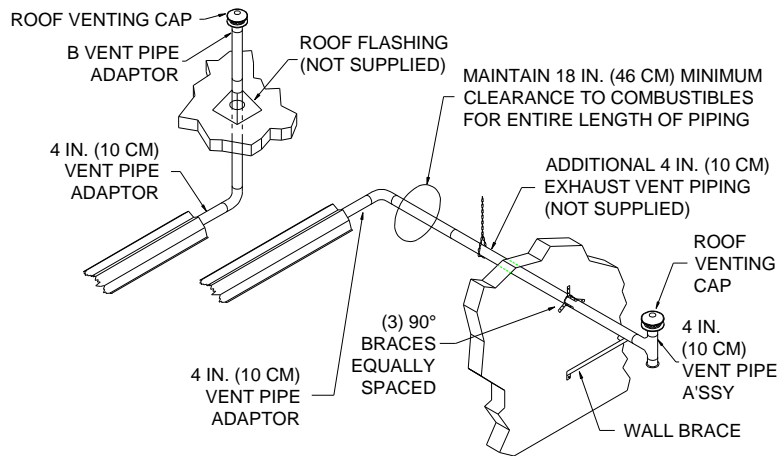
| INDIRECT INDOOR VENTING | INSIDE OF BUILDING | | | | | | | | | | | | | | | | | | | | | | | | | | | | | | | |
|--|--|---------------------------|----------------------|--|------------------------------|----------------------|---------------------------|----------------------|--------------------|-------------|--------------------|-------------|---------------------|--------------|---------------------|--------------|---------------------|--------------|-----|---------|---|-----|-----|---------|-------|-----|-----|---------|--|-----|----------|-----|
| <ul style="list-style-type: none"> A heater that is vented indoors is classified as Category I by the National Fuel Gas Code. At least 4 CFM of exhaust per 1,000 BTUH (.38 m³ per minute per kW) must be provided. Supply and exhaust air must be provided by natural or mechanical means. For Canada see CANADIAN ADDENDUM section. For supply and exhaust air by natural means, fresh air/ exhaust openings are required. Fresh air openings should be below the indoor venting kit. Exhaust openings must be located above the heaters. For supply and exhaust air by mechanical means, provision must be made so the flow of gas to the heater is allowed only when the mechanical exhaust is in operation. Combustion air must not be provided directly from outdoors to the inlet air collar on the burner. (For exceptions see COMBUSTION AIR SUPPLY). | <p>CLEARANCE TO COMBUSTIBLES (CTC) MUST BE MAINTAINED FROM EXHAUST END OF HEATER.</p> <table border="0"> <tr> <td>RATING MBTUH (kW)</td> <td>CTC*</td> </tr> <tr> <td>85 / 65 (25 / 19)</td> <td>30" (76 cm)</td> </tr> <tr> <td>100 / 65 (29 / 19)</td> <td>30" (76 cm)</td> </tr> <tr> <td>125 / 95 (37 / 28)</td> <td>38" (97 cm)</td> </tr> <tr> <td>150 / 100 (44 / 29)</td> <td>48" (122 cm)</td> </tr> <tr> <td>175 / 125 (51 / 37)</td> <td>58" (147 cm)</td> </tr> <tr> <td>200 / 145 (59 / 42)</td> <td>68" (173 cm)</td> </tr> </table> <p>*CTC is measured from the end of the Indoor Venting Kit.</p>  <p>Minimum clearance from ceiling: 15" (38cm) is measured from top of reflector.</p> | | | | RATING MBTUH (kW) | CTC* | 85 / 65 (25 / 19) | 30" (76 cm) | 100 / 65 (29 / 19) | 30" (76 cm) | 125 / 95 (37 / 28) | 38" (97 cm) | 150 / 100 (44 / 29) | 48" (122 cm) | 175 / 125 (51 / 37) | 58" (147 cm) | 200 / 145 (59 / 42) | 68" (173 cm) | | | | | | | | | | | | | | |
| RATING MBTUH (kW) | CTC* | | | | | | | | | | | | | | | | | | | | | | | | | | | | | | | |
| 85 / 65 (25 / 19) | 30" (76 cm) | | | | | | | | | | | | | | | | | | | | | | | | | | | | | | | |
| 100 / 65 (29 / 19) | 30" (76 cm) | | | | | | | | | | | | | | | | | | | | | | | | | | | | | | | |
| 125 / 95 (37 / 28) | 38" (97 cm) | | | | | | | | | | | | | | | | | | | | | | | | | | | | | | | |
| 150 / 100 (44 / 29) | 48" (122 cm) | | | | | | | | | | | | | | | | | | | | | | | | | | | | | | | |
| 175 / 125 (51 / 37) | 58" (147 cm) | | | | | | | | | | | | | | | | | | | | | | | | | | | | | | | |
| 200 / 145 (59 / 42) | 68" (173 cm) | | | | | | | | | | | | | | | | | | | | | | | | | | | | | | | |
| DIRECT OUTDOOR VENTING | THROUGH THE WALL AND ROOF | | | | | | | | | | | | | | | | | | | | | | | | | | | | | | | |
| <ul style="list-style-type: none"> A heater vented directly outdoors is classified as Category III by the National Fuel Gas Code. It may be vented through either the roof or wall singularly or in conjunction with no more than one other heater with a single thermostat. Use 4 in. (10.2 cm) I.D. single wall stainless or galvanized sheet metal pipe of not less than 26 gauge (.044 cm) (or other factory approved materials). Place seam at the top. Use RTV silicone adhesive sealant liberally at all vent pipe joints. Use three (3) #6 sheet metal screws per vent pipe joint 120° apart starting at the top. 1 inch (2.5 cm) thick pipe insulation wrapped around the single wall sheet metal pipe is recommended. By code, the use of dual wall pipe for outdoor venting is limited to appliances with neutral or negative pressures. Local authorities may waive this provision since the heaters are approved for indoor venting with proper exhaust and leakage due to condensation being greatly reduced. Be certain to get approval for either type of vent piping from local authorities. Vent pipes must be well supported due to the extra stress that occurs during expansion of the unit when operating. Vent caps must be identical, or equal, to those specified in this manual which are of the Metalbestos brand. This is critical to the heater's operation and to maintain C.S.A. certification. Heater must not be vented in between buildings less than 10 feet (3.0 m) apart or above public walkways, doors or windows. | <p>ROOF VENTING CAP MUST BE 6 IN. (15 CM) HIGHER THAN SNOW DEPTH.</p>  | | | | | | | | | | | | | | | | | | | | | | | | | | | | | | | |
| IMPORTANT | DISTANCES OF EXHAUST VENT FROM: | | | | | | | | | | | | | | | | | | | | | | | | | | | | | | | |
| <ul style="list-style-type: none"> Use a factory supplied 4 in. (10.2 cm) Vent Pipe Adaptor to connect venting to exhaust end of tube. Use RTV silicone adhesive sealant and three (3) self-drilling screws to attach. See the OVERVIEW DRAWINGS section for more venting information. | <table border="1"> <thead> <tr> <th></th> <th>BELOW Inches (cm)</th> <th>HORIZONTAL Inches (cm)</th> <th>ABOVE Inches (cm)</th> </tr> </thead> <tbody> <tr> <td>Door</td> <td>N/A</td> <td>48 (122)</td> <td>N/A</td> </tr> <tr> <td>Window</td> <td>48 (122)</td> <td>12 (30)</td> <td>N/A</td> </tr> <tr> <td>Gravity Air Inlet</td> <td>N/A</td> <td>N/A</td> <td>12 (30)</td> </tr> <tr> <td>Forced Air Inlet Within 10 ft. (3.0 m)</td> <td>N/A</td> <td>N/A</td> <td>36 (91)</td> </tr> <tr> <td>Grade</td> <td>N/A</td> <td>N/A</td> <td>12 (30)</td> </tr> <tr> <td>Gas & Electric Meters, Regulators & Relief Valves</td> <td>N/A</td> <td>48 (122)</td> <td>N/A</td> </tr> </tbody> </table> | | | | | BELOW Inches (cm) | HORIZONTAL Inches (cm) | ABOVE Inches (cm) | Door | N/A | 48 (122) | N/A | Window | 48 (122) | 12 (30) | N/A | Gravity Air Inlet | N/A | N/A | 12 (30) | Forced Air Inlet Within 10 ft. (3.0 m) | N/A | N/A | 36 (91) | Grade | N/A | N/A | 12 (30) | Gas & Electric Meters, Regulators & Relief Valves | N/A | 48 (122) | N/A |
| | BELOW Inches (cm) | HORIZONTAL Inches (cm) | ABOVE Inches (cm) | | | | | | | | | | | | | | | | | | | | | | | | | | | | | |
| Door | N/A | 48 (122) | N/A | | | | | | | | | | | | | | | | | | | | | | | | | | | | | |
| Window | 48 (122) | 12 (30) | N/A | | | | | | | | | | | | | | | | | | | | | | | | | | | | | |
| Gravity Air Inlet | N/A | N/A | 12 (30) | | | | | | | | | | | | | | | | | | | | | | | | | | | | | |
| Forced Air Inlet Within 10 ft. (3.0 m) | N/A | N/A | 36 (91) | | | | | | | | | | | | | | | | | | | | | | | | | | | | | |
| Grade | N/A | N/A | 12 (30) | | | | | | | | | | | | | | | | | | | | | | | | | | | | | |
| Gas & Electric Meters, Regulators & Relief Valves | N/A | 48 (122) | N/A | | | | | | | | | | | | | | | | | | | | | | | | | | | | | |
| | MAXIMUM LENGTHS OF VENT PIPE | | | | | | | | | | | | | | | | | | | | | | | | | | | | | | | |
| | <ul style="list-style-type: none"> All two-stage models maximum length of vent pipe is 20 linear feet (6m) and one 90° elbow. | | | | | | | | | | | | | | | | | | | | | | | | | | | | | | | |

WINDY CONDITIONS NOTES

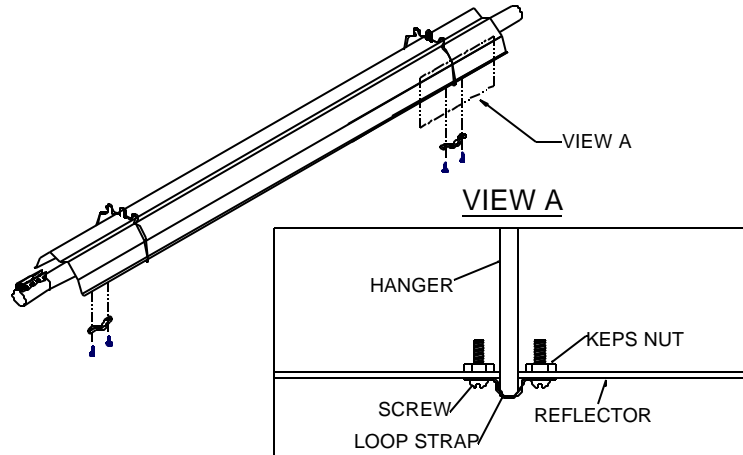
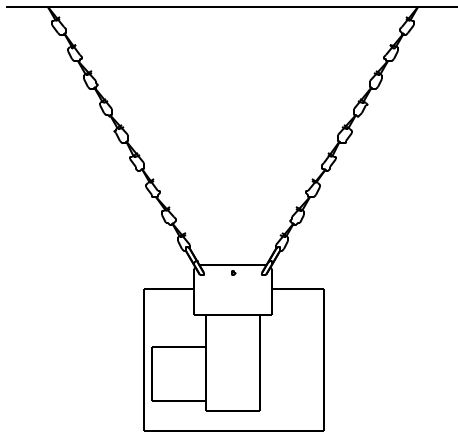

NEAR LOADING DOCK, AIRPLANE HANGAR DOORS, OR OTHER WINDY AREAS FASTEN REFLECTORS TO HANGERS WITH LOOP STRAPS, SCREWS AND KEPS NUTS.

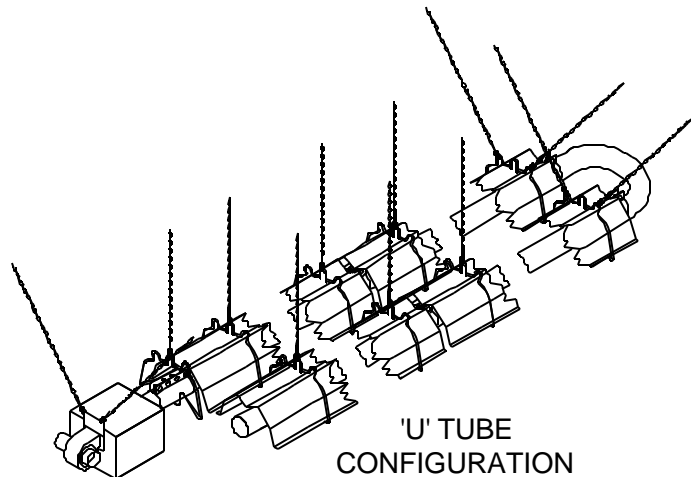
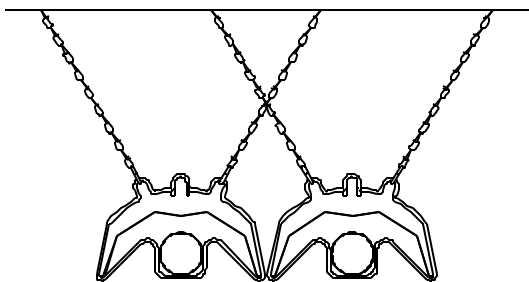
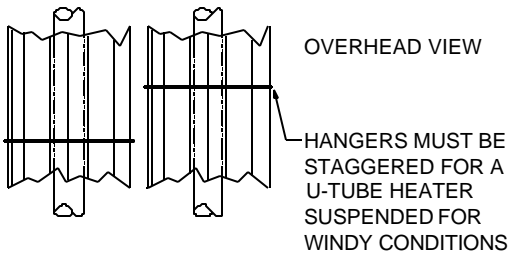
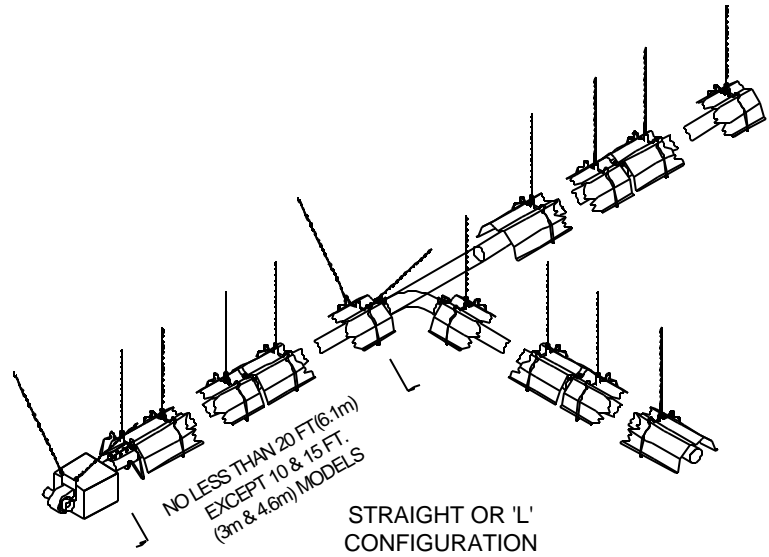
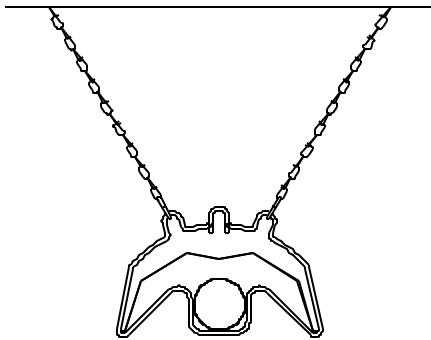

U-TUBE INSTALLATION

- A heater may be installed as a U-Tube with its radiant tubes horizontal or with the heat exchanger angled above the combustion chamber as illustrated by the drawing below.
- When radiant tubes are horizontal, reflectors may be individually rotated from 0 to 30 degrees or from 0 to 45 degrees depending on the model installed. (Refer to CLEARANCE TO COMBUSTIBLES section).

HORIZONTAL

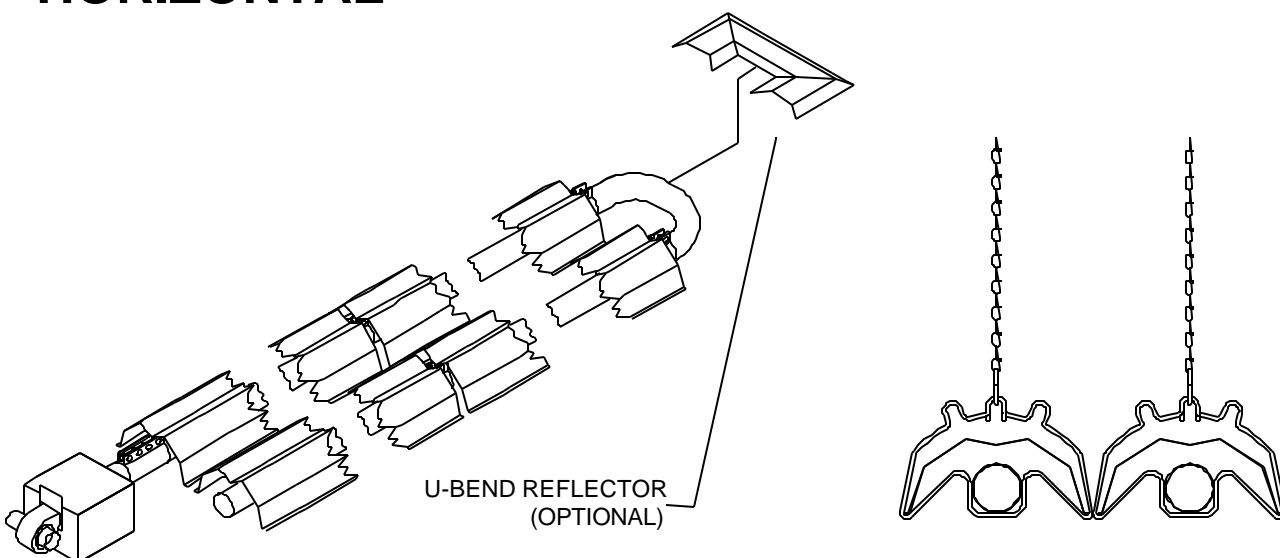

ANGLED

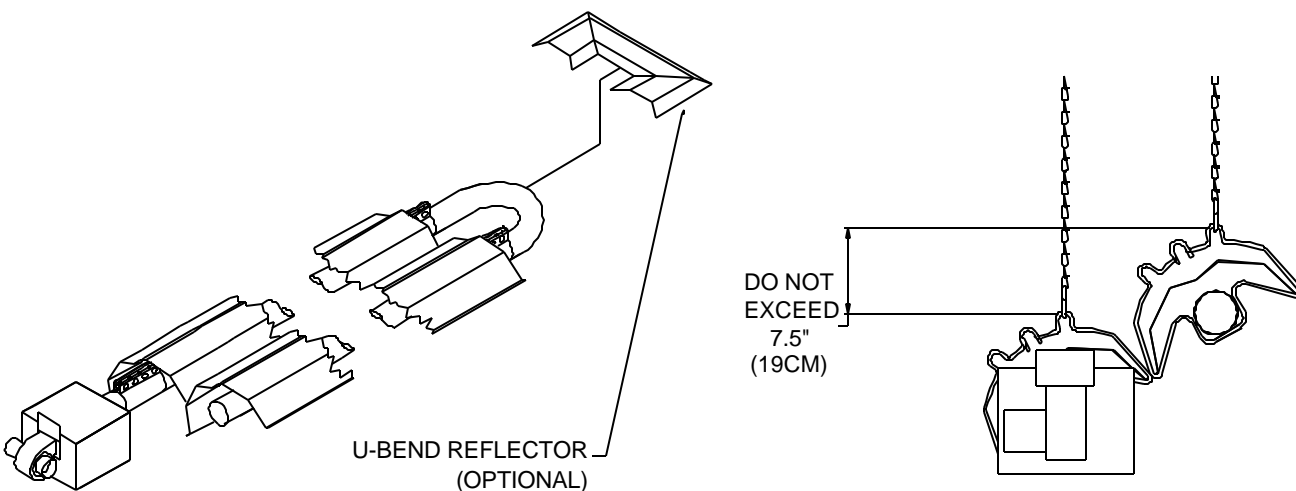

INSTALLATION (1 OF 2)

CAUTION

- **DO NOT** use gas piping or electrical conduit to provide any type of support for the heater's suspension.
- Means of suspension **MUST BE** able to support twice the weight of the heater, securely fastened to the building's structure, and allow for expansion during its operation.
- Chain for suspension **MUST BE** 12 in. (31cm) minimum in length and be 1/0 TENSO with a minimum working load rating of 200 lbs. (90.7 kg).
- The "S" hook **MUST BE** Chicago Hardware no. 5 or equal and carry a 70 pound (32kg) maximum load.

STEP

1

- Use a taut string in the planning of suspension points to maintain straightness over the length of the system. Make true right angles if elbows are used.
- Check the BASIC SYSTEM CONFIGURATIONS section for the general orientation of components matching the model number of your system.
- Identify all components in the COMBUSTION CHAMBERS and HEAT EXCHANGERS sections.
- U-type systems use a 180-degree U-bend. See U-TUBE INSTALLATION section.

STEP

2

- Install chain for suspension of tubes and reflectors.
- The suspension points for each 10-foot (3.0m) tube should be a minimum of 4 feet (1.2m) and a maximum of 8 feet (2.4m) apart.
- Install a chain to be positioned at the joint between the combustion chamber and the burner.
- Install an additional suspension point, for a required safety chain at the back of the burner box 17.5 in. (44cm) from the joint between the combustion chamber and the burner. The burner safety chain should have an additional 6 in. (15cm) of length added to allow for slack.
- Install tube/reflector hangers. Slip one end of the S-hook through the last chain link and the other end through the tube/reflector hanger.
- **IMPORTANT: Crimp both ends of the S-hook closed!**

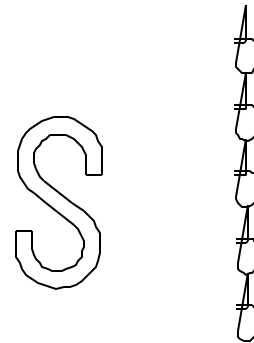

STEP

3

- Lift the exhaust end heat exchanger into place with the weld seam facing up and suspend it in the tube/reflector hangers already in position. The exhaust end heat exchanger is marked "EXHAUST END". The designation of the exhaust end tube (H5, H9 or H1) is determined by burner size and system length as per the BASIC SYSTEM CONFIGURATIONS section.

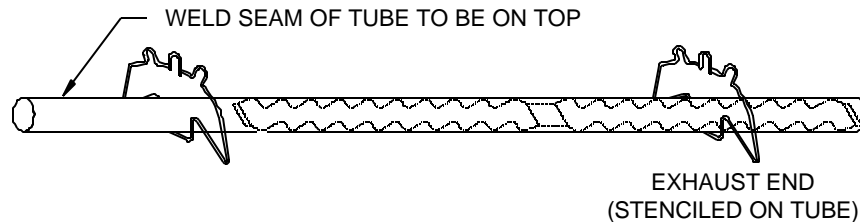

STEP

4

- Install a tube clamp on the end **opposite** of the end marked "EXHAUST END". Orient clamp bolts on top.
- **Make sure the tube is inserted tight against the center stop inside the tube clamp.**
- Install factory supplied 4 in. (10.2 cm) Vent Pipe Adaptor onto the end of the tube stenciled "EXHAUST END". Use RTV silicone adhesive sealant and three (3) self-drilling screws to attach.
- Finish installing exhaust venting.

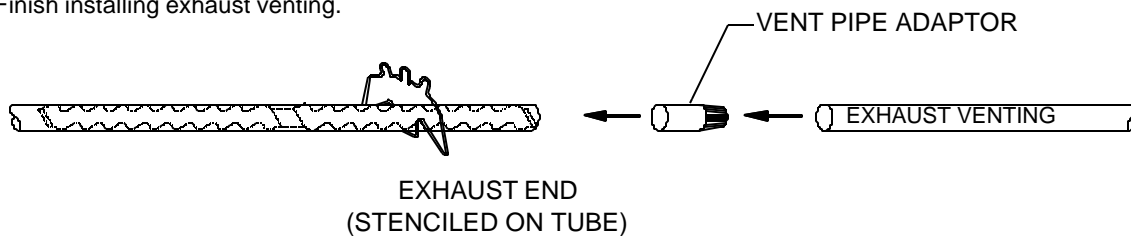

CAUTION

- Ensure the correct tubes are used in the correct order as per the BASIC SYSTEM CONFIGURATIONS section. Erratic, unstable operation may occur.

INSTALLATION (2 OF 2)

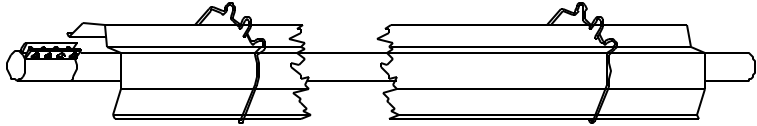
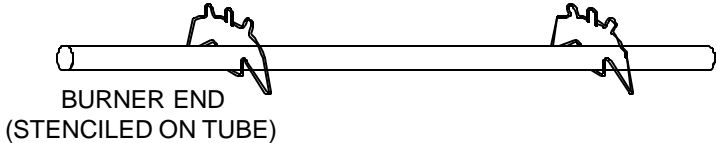
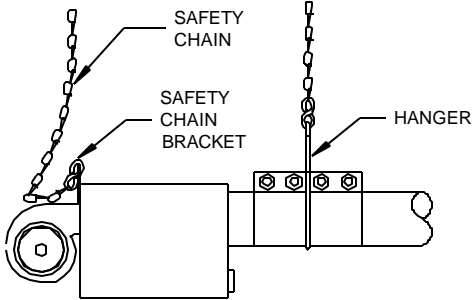
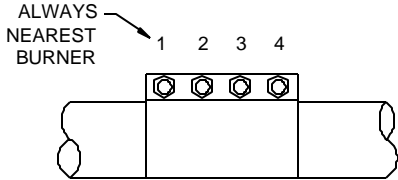
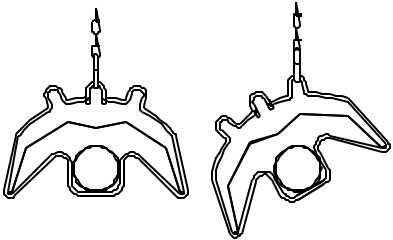
| | | | |
|---|--|--|---|
| STEP 5 | | <ul style="list-style-type: none"> Lift the remaining heat exchanger(s), for heaters longer than 25 feet (7.6 m), into place with the weld seam facing up in the tube/reflector hangers previously installed. Insert the end of the tube into the tube clamp of the previously hung heat exchanger. Be certain that the tube is inserted to the stop inside the tube clamp. Tighten the tube clamp, sufficiently but not permanently, to make sure it does not come loose during installation. Install a tube clamp on the end of each heat exchanger after it is installed. Install the reflector inside the hangers. (Gloves are suggested so as not to soil the shiny underside.) | |
|  | | | |
| STEP 6 | | <ul style="list-style-type: none"> Lift the combustion chamber, for heaters of 20 feet (6.1 m) or more, into place with the weld seam facing up in the tube/reflector hangers previously installed so that the end of the tube stenciled "BURNER END" is where the burner will be installed. The combustion chamber is aluminized steel [C2, C4(painted black)]. Insert the other end into the tube clamp on the previous heat exchanger. Be certain that the tube is inserted to the center stop in the clamp. Tighten the tube clamp, sufficiently but not permanently, to make sure it does not come loose during installation. Install a tube clamp on the burner end of the combustion chamber after it is installed. Install the reflectors inside the hangers. (Gloves are suggested so as not to soil the shiny underside.) | |
|  | | | |
| STEP 7 | | <ul style="list-style-type: none"> Install a tube/reflector hanger around the center of this tube clamp on the burner end of the combustion chamber. This hanger will provide the main support for the burner. Lift the burner into place and suspend it by inserting the S-hook of the safety chain into the center hole of the safety chain bracket, and then crimp both ends of the hook closed. Insert the burner tube into the tube clamp at the burner end of the combustion chamber. Make sure the burner tube is inserted against the center stop inside of the tube clamp. The safety chain for the burner has 6" (15 cm) of slack. It is NOT taut. Then, tighten the clamp as described in step 8. |  |
| STEP 8 | | <ul style="list-style-type: none"> Tighten all tube clamp bolts on all tube clamps to 65 ft.-lbs. (88 Nm) with a torque wrench in a 2, 3, 4, 1 sequence. See OVERVIEW DRAWINGS section for more information. |  |
| STEP 9 | | <ul style="list-style-type: none"> Reflectors must not be angle mounted more than 30° from horizontal for models with a rate of 125 MBTUH (37 kW) and below, or 45° from horizontal for all other models. If located near a door or windy area, fasten reflectors to tube/reflector hangers with tek screws. See WINDY CONDITION NOTES. |  |
| CAUTION | | IMPORTANT | |
| <ul style="list-style-type: none"> Make sure all chains are plumb and vertical to prevent damage to tubes. | | <ul style="list-style-type: none"> Connect the gas supply as instructed in the GAS SUPPLY AND GAS PRESSURE section. Connect the electrical supply as instructed in the ELECTRICAL SUPPLY AND THERMOSTATIC CONTROL section. | |

ELECTRICAL SUPPLY AND THERMOSTATIC CONTROL (1 OF 2)

| ELECTRICAL SUPPLY | | | |
|--|----------|--|-------------------|
| <ul style="list-style-type: none"> Voltage: 120VAC - 1 phase - 60 Hz. Maximum Amps: 1.3 Amps. Flame safety: Electronic. Ignition: Direct Spark. Wiring must be electrically grounded in accordance with the latest edition of the National Electric Code (ANSI/NFPA 70) or local code legally authorized. Electrical power takeoff must be connected to a separately fused circuit with a disconnect, and must be properly polarized and grounded to the heaters power cord. Do not run wiring over the heaters or in direct view of radiant heat. If any of the wiring supplied must be replaced use type 16 AWG (1.0mm²), or equivalent with 2/64" (.08 cm) insulation and a minimum insulation temperature of 302°F (150°C). | | | |
| 24 VAC THERMOSTATIC CONTROL: ONE HEATER ON A THERMOSTAT | | | |
| <p>TWO-STAGE THERMOSTAT</p> <p>FIRST STAGE HEAT 24 VAC OUTPUT W1 SECOND STAGE HEAT W2 24 VAC OUTPUT</p> <p>24 VAC INPUT R NEUTRAL INPUT C</p> | | <p>HEATER</p> <p>W1 LOW HEAT INPUT W2 HIGH HEAT INPUT</p> <p>R 24 VAC OUTPUT TO THERMOSTAT C NEUTRAL TO THERMOSTAT</p> | |
| <p>USE 18/4 SOLID CLASS 2 THERMOSTAT CABLE BETWEEN THERMOSTAT AND HEATER #1. MAXIMUM LENGTH OF 18 AWG (0.8mm²) THERMOSTAT CABLE IS 100 FT. (30M).</p> <p>LEGEND _____ WIRING ON HEATER - - - - - WIRING BY OTHERS</p> <p>DO NOT SHORT CIRCUIT THE "R" AND "C" TERMINALS TO PREVENT TRANSFORMER DAMAGE.</p> <p>GROUNDING ELECTRICAL POWER CORD 120 VAC - 1 PHASE - 60 HZ</p> | | | |
| 24 VAC THERMOSTATIC CONTROL: TWO HEATERS ON A THERMOSTAT | | | |
| <p>TWO-STAGE THERMOSTAT</p> <p>FIRST STAGE HEAT 24 VAC OUTPUT W1 SECOND STAGE HEAT W2 24 VAC OUTPUT</p> <p>24 VAC INPUT R NEUTRAL INPUT C</p> | | <p>HEATER #1</p> <p>W1 LOW HEAT INPUT W2 HIGH HEAT INPUT</p> <p>R 24 VAC OUTPUT TO THERMOSTAT C NEUTRAL TO THERMOSTAT</p> | |
| <p>USE 18/4 SOLID CLASS 2 THERMOSTAT CABLE BETWEEN THERMOSTAT AND HEATER #1. MAXIMUM LENGTH OF 18 AWG (0.8mm²) THERMOSTAT CABLE IS 100 FT. (30M).</p> <p>LEGEND _____ WIRING ON HEATER - - - - - WIRING BY OTHERS</p> <p>DO NOT SHORT CIRCUIT THE "R" AND "C" TERMINALS TO PREVENT TRANSFORMER DAMAGE.</p> <p>GROUNDING ELECTRICAL POWER CORD 120 VAC - 1 PHASE - 60 HZ</p> | | | |
| <p>HEATER #2</p> <p>W1 LOW HEAT INPUT W2 HIGH HEAT INPUT</p> <p>R 24 VAC OUTPUT TO THERMOSTAT C NEUTRAL TO THERMOSTAT</p> | | <p>USE 18/3 SOLID CLASS 2 THERMOSTAT CABLE BETWEEN THERMOSTAT AND HEATER #2. MAXIMUM LENGTH OF 18 AWG (0.8mm²) THERMOSTAT CABLE IS 100 FT. (30M).</p> <p>LEGEND _____ WIRING ON HEATER - - - - - WIRING BY OTHERS</p> <p>DO NOT SHORT CIRCUIT THE "R" AND "C" TERMINALS TO PREVENT TRANSFORMER DAMAGE.</p> <p>GROUNDING ELECTRICAL POWER CORD 120 VAC - 1 PHASE - 60 HZ</p> | |
| GENERAL INSTALLATION NOTES | | | |
| <ul style="list-style-type: none"> Locate the thermostat as specified in the heating plan. If it is not in the heating plan, follow the instructions provided with the thermostat. If instructions are not provided with the thermostat, locate it four to five feet above the floor where it will not be directly affected by the heater, outside drafts, the sun, or other equipment heat. A location that best represents the average temperature of the room is the most desirable. If two heaters are installed on a common exhaust vent they must be controlled by the same thermostat. | | | |
| ! WARNING ! MULTIPLE HEATERS ON A THERMOSTAT | | | |
| <ul style="list-style-type: none"> No more than two heaters are authorized to operate with one thermostat. DO NOT hook up the thermostat wire to the "R" terminal of the second heater. Failure to comply with this instruction would allow 24 VAC to back-feed the transformer and produce 120 VAC in the second heater when its power cord is unplugged creating a safety hazard to service personnel. Use only three-wire thermostat cable (red, white, and green) to operate the second heater. When performing service on a heater that is wired to another heater by the thermostat wires, disconnect the thermostat wires from the heater being serviced. | | | |
| MAXIMUM NUMBER OF HEATERS FOR TWO-STAGE THERMOSTAT | | | |
| Part No. | Volts AC | Amps | Number of Heaters |
| 0002-42-156 | 24 | 1.0 | 2 |
| TERMINAL BOARD LOCATION | | | |
| <p>The terminal board is located on the burner next to the blower, or under the burner cover when a blower enclosure is used. See THERMOSTAT WIRING WHEN BLOWER ENCLOSED section.</p> | | | |
| TERMINAL BOARD: ONE HEATER ON A THERMOSTAT, OR HEATER #1 WITH TWO HEATERS ON A THERMOSTAT | | | |
| | | | |
| TERMINAL BOARD: HEATER #2 WITH TWO HEATERS ON A THERMOSTAT | | | |
| | | | |

ELECTRICAL SUPPLY AND THERMOSTATIC CONTROL (2 OF 2)

SEQUENCE OF OPERATION

- When starting up or servicing this heater, wait 5 minutes before attempting to light heater or between attempts to light heater to allow any purged fuel gas to dissipate.
- Thermostat calls for heat (high or low), the blower starts for a 30-second prepurge.
- The blower reaches operational speed and the airflow switch (normally open) contacts close confirming combustion air and exhaust vent back pressure are normal.
- Once the prepurge is complete the Ignition Detection Control (IDC) initiates a trial-for-ignition during which a spark is developed at the ignitor and the gas valve opens. The burner ignites and the IDC senses current through the flame sensor rod. The IDC shuts off the spark circuit and monitors flame presence.
- Low heat is a closed circuit W1 to R at the burner terminal board.
- High heat is a closed circuit W1 and W2 to R at the burner terminal board.
- Should flame failure occur a delay time begins followed by a trial-for-ignition attempt to light the burner. If flame is re-established, normal operation resumes. If not, the burner will repeat the delay and the trial-for-ignition. If the burner fails to light after the third trial for ignition, the IDC will de-energize the gas valve and go into lockout mode.
- For manual lockout recovery, reset thermostat below ambient temperature or disconnect electrical power supply for five (5) seconds.
- The IDC will automatically reset itself after 30 minutes.
- When the thermostat is satisfied, the gas valve closes and a 120-second post-purge begins before the blower stops.

WIRING CONNECTION DIAGRAM

If any of the original wire as supplied with the appliance must be replaced, it must be replaced with wiring material having a temperature rating of at least 302°F (150°C) and shall have a minimum size of 16 AWG (1.0mm²).

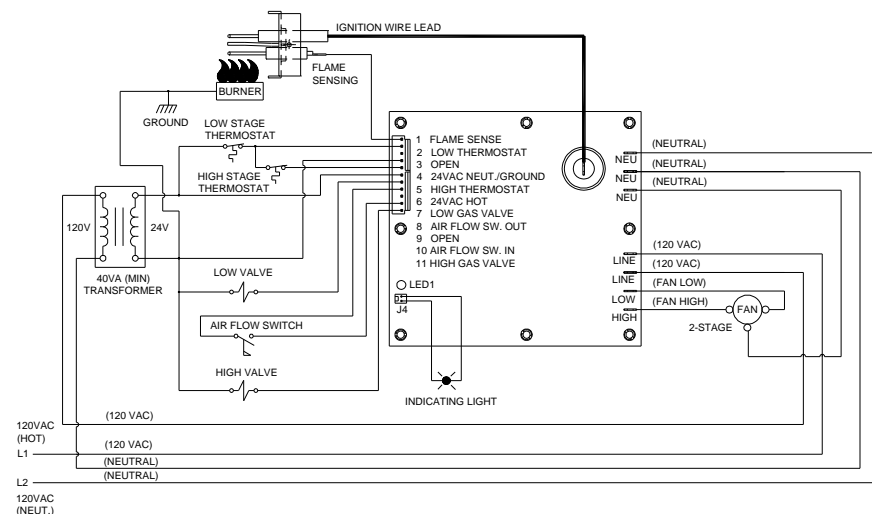

WIRING SCHEMATIC LADDER DIAGRAM

If any of the original wire as supplied with the appliance must be replaced, it must be replaced with wiring material having a temperature rating of at least 302°F (150°C) and shall have a minimum size of 16 AWG (1.0mm²).

120 VAC - 60 HZ - 1 PHASE
 HEATER MAXIMUM CURRENT DRAW = 1.3 AMPS.
 TOTAL HEATER POWER CONSUMED = 156 VA

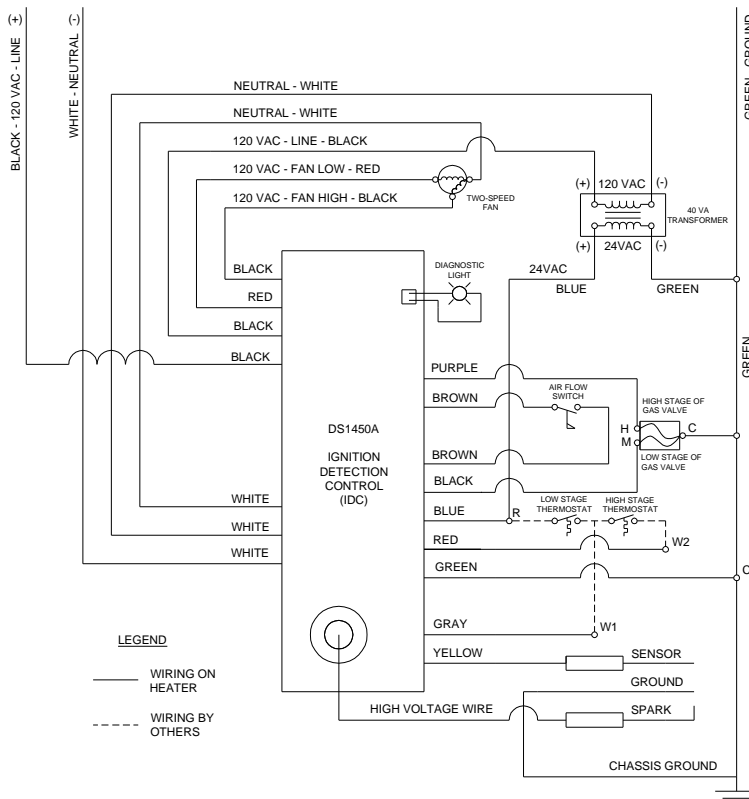

! WARNING !

- 120 VAC AND 24 VAC ARE STILL PRESENT AT THE IDC THOUGH THE THERMOSTAT IS SATISFIED.**

DIAGNOSTIC LIGHT CODES:

| | |
|-----------|--|
| OFF | No power or internal fault |
| ON | Normal operation |
| 1 Flash | Operation detected out of sequence |
| 2 Flashes | Ignition trial lockout |
| 3 Flashes | Flame loss lockout |
| 4 Flashes | Pressure switch contacts did not closed or are stuck closed. |

THERMOSTAT WIRING WHEN BLOWER ENCLOSED

FIELD WIRING FOR 24-VOLT THERMOSTAT FOR 2-STAGE BURNER WITH BLOWER ENCLOSURE

STEP 1:

Remove burner cover.

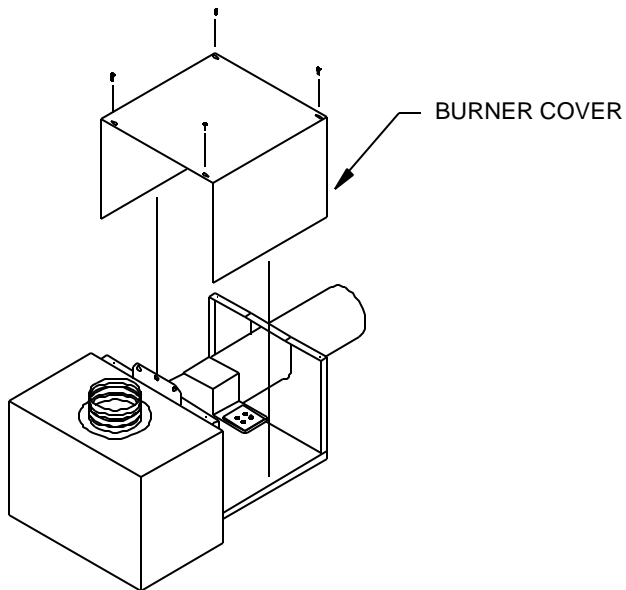

STEP 2:

Route approximately 14" (36cm) of 4-wire thermostat cable into burner by way of strain relief bushing located at bottom of burner wrapper.

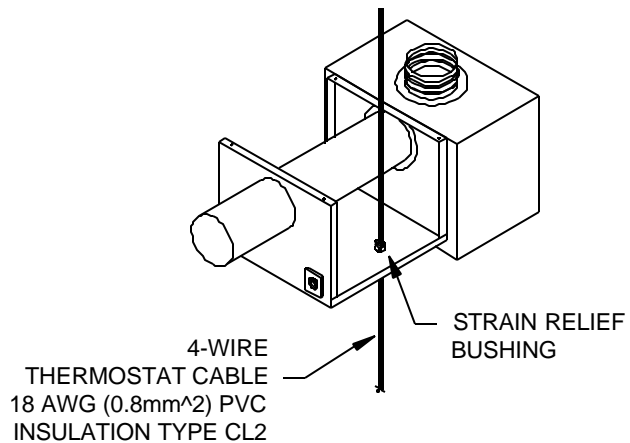

STEP 3:

Route 4-wire thermostat cable under casing tube and up to connect to terminal board. Loop wires above terminal board enough to leave slack to avoid them rubbing against terminal board mounting bracket. Replace burner cover.

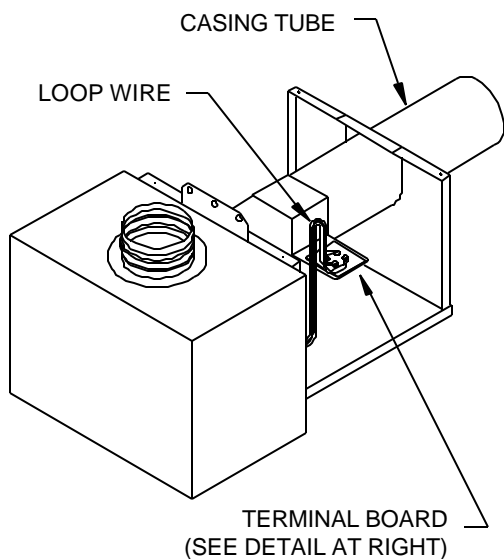

TERMINAL BOARD: ONE HEATER ON A THERMOSTAT, OR HEATER #1 WITH TWO HEATERS ON A THERMOSTAT

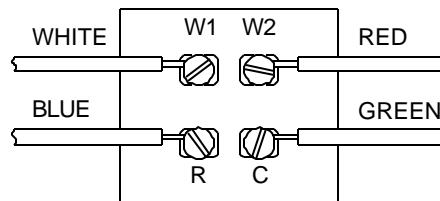

TERMINAL BOARD: HEATER #2 WITH TWO HEATERS ON A THERMOSTAT

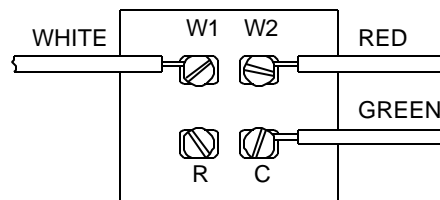

GAS VALVE

GAS VALVE TOP VIEW

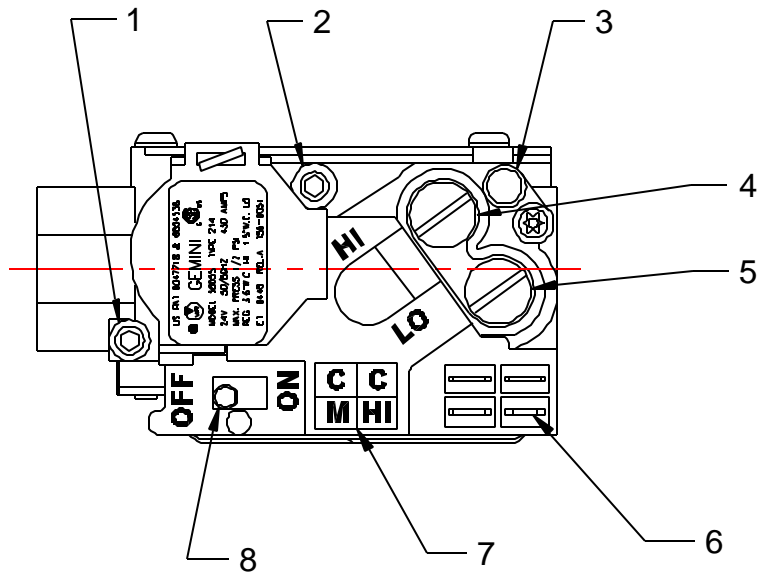

GAS VALVE FEATURES IDENTIFICATION KEY

1. INLET TEST POINT "IN P" inlet pressure post: 3/32" (2.3mm) hex head set screw (loosen, but **Do Not Remove** to measure pressure), accepts 1/4" (6mm) ID hose connection.
2. OUTLET TEST POINT "OUT P" outlet pressure post: 3/32" (2.3mm) hex head set screw (loosen, but **Do Not Remove** to measure pressure), accepts 1/4" (6mm) ID hose connection.
3. Vent.
4. Second stage regulator cover: regulator adjustment beneath this screw.
5. First stage regulator cover: regulator adjustment beneath this screw.
6. Quick disconnect electrical terminals.
7. Labels for quick disconnect electrical terminals.
8. ON / OFF switch.

GAS VALVE ISOMETRIC VIEW

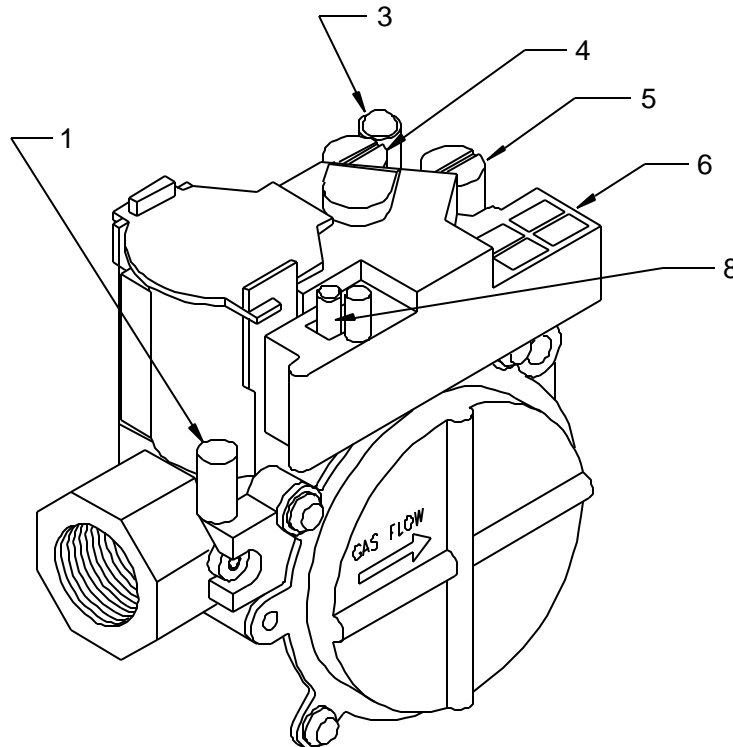

GAS SUPPLY AND GAS PRESSURE

| GAS SUPPLY PIPING | | | | INLET GAS PRESSURE | |
|--|---------------------|---------------------------|---|--|-------------------------------|
| <ul style="list-style-type: none"> Piping must be installed in accordance with local codes and/or ANSI Z223.1 (NFPA 54) – latest edition, National Fuel Gas Code. Piping must have drip leg and a ground joint union. All pipe connections must have pipe joint compound, resistant to LP/propane gas action. Isolate regulators, flexible gas connectors, and heaters during high-pressure leak testing. All gas lines must be purged before startup. Use only agency approved flexible gas connector with shut-off cock for connecting to heater. (SEE CAUTION) Use swing or swivel joint in addition to rigid piping if local codes prohibit use of a flexible gas connector. Local codes may require additional shut-off cock ahead of drip leg. | | | | <ul style="list-style-type: none"> Inlet gas pressure must be measured on the inlet side of the valve at Test Point 'IN P' and must conform to the following: | |
| | | | | GAS TYPE | PRESSURE in. WC (cm WC) |
| | | | | MINIMUM: | |
| | | | | NATURAL GAS | 7 (18) |
| | | | | LP/PROPANE GAS | 11 (28) |
| MAXIMUM: | | | | | |
| NATURAL GAS LP/PROPANE GAS | 14 (35) | | | | |
| CAUTION: "LAZY LOOP" | | | | | |
| <ul style="list-style-type: none"> Stress from expansion and contraction of heater may cause excessive wear on the gas connection. If local codes permit, flexible gas connectors must be in a "Lazy Loop", arrangement as shown on drawing below. It is important to maintain dimensions on drawing below. | | | | | |
| Heater length | Expansion | Heater length | Expansion | <h3 style="text-align: center;">HIGH INLET GAS PRESSURE</h3> <ul style="list-style-type: none"> For pressure greater than 14 in. WC (35 cm WC) a positive lockout type high-pressure regulator must be installed in the gas line ahead of the burner. Always check local codes for gas venting requirements for high-pressure regulators. Over-protection pressure devices (OPD's) may be required in certain jurisdictions. High inlet gas pressure regulators will NOT turn off the flow of gas. | |
| 20 ft (3.1-6.1 m) | 1.1 in (2.8 cm) | 45-50 ft (13.7-15.2 m) | 2.1 in (5.3 cm) | | |
| 25-30 ft (7.6-9.1 m) | 1.5 in (3.8 cm) | 55-60 ft (16.8-18.3 m) | 2.4 in (6.1 cm) | | |
| 35-40 ft (10.7-12.2 m) | 1.8 in (4.6 cm) | 65-70 ft (19.9-21.3) | 2.7 in (6.7 cm) | | |
| GAS PRESSURE MEASUREMENTS | | | | MANIFOLD OUTLET GAS PRESSURES | |
| <ul style="list-style-type: none"> Use only water or red oil manometer to make measurements –NOT A DIAL GAUGE. Make ALL measurements and adjustments when this heater and ALL other gas burning equipment connected to the same gas meter are operating at maximum capacity. | | | | <ul style="list-style-type: none"> Fluctuations in inlet pressure can alter manifold pressures. The high manifold pressure must be set first, before setting the low manifold pressure. See drawing below for manifold pressure adjustment locations. See GAS VALVE section. Loosen, Do Not Remove, the screw from Test Point 'OUT P'; press 1/4" (6mm) manometer tube over the fitting. Remove the slotted cap screws at the 'HI' and 'LO' markings. Turn adjustment screw clockwise to increase pressure or counterclockwise to decrease pressure. Screws require a flat head screwdriver and a 3/32" (2.38mm) hex key. | |
| | | | | | |
| HIGH MANIFOLD PRESSURE | RATING: MBTUH (kW) | | LOW MANIFOLD PRESSURE | | |
| 5.0 in. WC (12.7 cm WC) (Set high manifold pressure before setting low manifold pressure.) | 85 / 65 (25 / 19) | | 3.0 in. WC (7.6 cm WC) | | |
| | 100 / 65 (29 / 19) | | Natural 2.3 in. WC (5.8 cm WC) – Propane 2.5 in. WC (6.4 cm WC) | | |
| | 125 / 95 (37 / 28) | | 3.0 in. WC (7.6 cm WC) | | |
| | 150 / 100 (44 / 29) | | 2.5 in. WC (6.4 cm WC) | | |
| | 175 / 125 (51 / 37) | | 2.6 in. WC (6.6 cm WC) | | |
| | 200 / 145 (59 / 42) | | 2.9 in. WC (7.4 cm WC) | | |
| <div style="display: flex; justify-content: space-between;"> <div style="width: 45%;"> <p>WHEN GAS PRESSURE EXCEEDS 14" W.C. (35 CM W.C.) A FIRST STAGE REGULATOR MUST BE INSTALLED.</p> </div> <div style="width: 45%;"> </div> </div> | | | | | |
| CAUTION | | | | | |
| Excessive torque on the burner gas inlet manifold pipe may cause damage to burner. Always use two (2) wrenches when making pipe connections. Important: Check for leaks with soap solution. DO NOT USE FLAMES! Leak test solution may cause corrosion. After test, water rinse to clear out any remaining solution. | | | | | |

STARTUP

| STARTUP | IMPORTANT |
|--|--|
| <ul style="list-style-type: none"> Remove the burner cover by removing the 4 sheet metal screws from the top side of the burner cover. Loosen the set screw from Test Point 'OUT P' and connect manometer. Refer to the GAS VALVE section and the GAS SUPPLY AND GAS PRESSURE section. Depress the dial on the gas valve, and make sure the gas valve is in the ON position. Turn on the electrical and gas supply and set the thermostat above the ambient room temperature, to call for heat. Refer to the ELECTRICAL SUPPLY AND THERMOSTATIC CONTROL section for proper sequence of operation. If the heater does not operate normally, refer to the BURNER TROUBLESHOOTING section to diagnose and correct the situation. Turn gas and electrical supply off, remove the manometer and tighten the set screw in Test Point 'OUT P' on the gas valve. Check again for gas leaks. Refer to GAS SUPPLY AND GAS PRESSURE section as needed. Cycle the heater several times by means of the thermostat, allowing at least five minutes between cycles. If the heater operates normally, replace the burner cover and screws. If the heater is vented directly outdoors, observe and verify the flue gases exiting from the exhaust vent are not impinging on building construction. | <ul style="list-style-type: none"> Check and, if necessary, adjust the manifold pressure! <div data-bbox="1015 268 1421 955" style="text-align: center;"> <h3>IGNITOR SPARK GAP</h3> <p>.156 IN. (3.96 CM) SPARK GAP ± 1/32 IN. (.08 CM)</p> <p>.208" (.53 CM) GROUND GAP REF.</p> </div> |

BURNER PARTS GUIDE

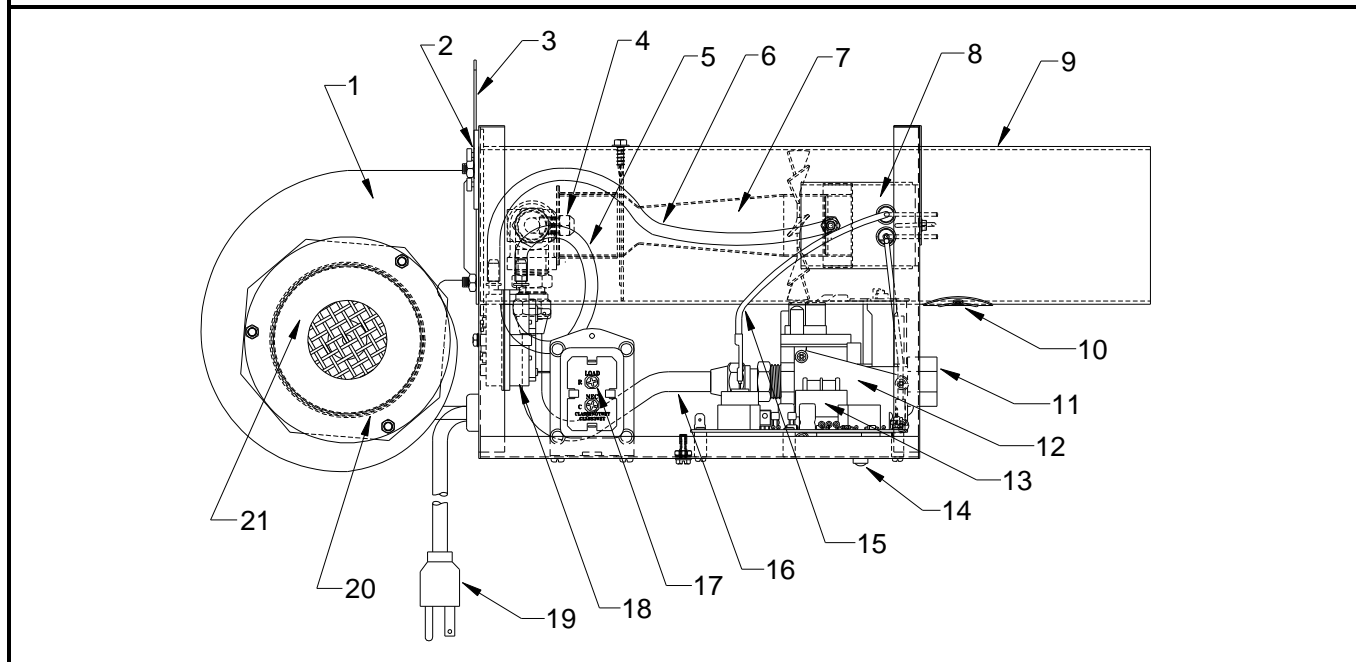

| | | |
|-------------------------|--------------------------------------|------------------------|
| 1. Blower | 8. Ignitor | 15. Ignition lead wire |
| 2. Terminal board | 9. Burner tube | 16. Gas Manifold |
| 3. Safety chain bracket | 10. Observation port | 17. Transformer |
| 4. Gas orifice | 11. 1/2" NPT gas inlet | 18. Airflow switch |
| 5. High side vinyl tube | 12. Gas valve | 19. Power cord |
| 6. Low side vinyl tube | 13. Ignition Detection Control (IDC) | 20. Inlet air collar |
| 7. Burner core assembly | 14. Indicator light LED | 21. Air orifice |

AIRFLOW SWITCH TUBING CONNECTIONS

- The switch "+" or "HIGH" side goes toward the blower side.
- The switch "-" or "LOW" side tube goes toward the ignitor side.

MAINTENANCE

- **FOR SAFETY REASONS, BEFORE PERFORMING ANY MAINTENANCE, DISCONNECT AND LOCKOUT THE ELECTRICAL SUPPLY, INCLUDING THE THERMOSTAT, BY POSITIVE MEANS.**
- All maintenance and/or repair ***MUST*** be performed by someone trained and qualified to work on gas and electrical equipment.
- Annual maintenance done prior to the beginning of each heating season is all that is usually necessary.
- In dirty, dusty, or wet atmospheres, it may be necessary to examine and perform needed maintenance at additional times during the middle of the heating season. Experience will dictate the frequency.
- Radiant tubes, combustion air ducting, and exhaust venting should be inspected to make sure that: suspension points are secure, tube clamp nuts are tight, heater is level, chains are plumb and taut (except for burner safety chain), vent pipe joints are properly sealed, "S" hooks are crimped closed, there is no excessive exterior buildup of dust or dirt, and make sure there are no restrictions such as bird or insect nests in the combustion air or vent piping or their terminations.
- Reflectors should be inspected to make sure they are clean and secure, as detailed in the INSTALLATION section. If dirty, reflectors should be removed and washed with isopropyl alcohol, Simple Green, or buffed with mild rubbing compound.
- On U-tube systems, the U-bend reflector support nuts should be inspected to make sure they are tight.
- Inspect the inside of the blower housing for excessive dust or dirt buildup on the impeller wheel and make sure the air orifice and the inlet air collar are properly attached. Check that the blower can come up to full speed.
- Remove the cover by removing the 4 sheet metal screws on top of the cover.
- Remove the ignitor by removing **ONLY** the end where the vinyl tubing is attached to the ignitor bracket; the fitting to which the vinyl tubing was connected; the ignition lead wire from the ignition detection control; and the sheet metal screw holding the ignitor bracket to the burner housing wall.
- Remove the ignitor carefully; its' electrodes make a ninety degree turn to the right.
- Clean the ignitor's porcelain insulation and check for cracks and proper gaps (see STARTUP section).
- Within the interior of the burner tube, examine the burner nozzle, primary air holes, main orifice and surrounding area for build up of dust or dirt. Clean if necessary.
- Reinstall the ignitor by following the previous instructions in reverse order.
- Examine the ignition detection control for overheating (warped plastic housing, discoloration, etc.)
- A visual inspection of gas valve, airflow switch, and wiring is adequate.
- Inside each clear vinyl tube used for air flow sensing is a small snubber (aluminum cylinder piece). Visually inspect for cleanliness.
- Clean any surfaces needed and correct any situations found in disrepair.
- Replace the cover and sheet metal screws.
- The blower motor is of the permanently lubricated type and requires no additional lubrication.
- Double check that the area under the heater is kept clear and free from combustible materials, gasoline, and other flammable vapors and liquids.
- Reconnect electrical supply and cycle the heater several times using the thermostat allowing (5) five minutes between cycles for proper operation.
- **WARNING: Do not operate heater with any part bypassed, with any part failed or in any possible situation that may compromise safety. Personal injury, death, and/or property damage could result.**

TROUBLESHOOTING

| Check for symptoms and possible causes in the order presented from the top of this chart to the bottom. | | |
|---|--|---|
| SYMPTOM | POSSIBLE CAUSE | CORRECTIVE ACTION |
| New Installation. | 1. Heaters not isolated during high pressure leak testing. | 1. Replace combination gas valves on each heater. |
| | 2. All gas lines not completely bled of air. | 2. Disconnect flex hose at each heater until gas is present. Connect flex hose and leak test. |
| | 3. External regulator reversed. | 3. Remove external regulator and install properly. |
| Gas Odor. | 1. Gas pipe joints loose. | 1. Check joints with soap solution, tighten as needed. |
| Diagnostic light not ON. (Indicator light ON for normal operation). | 1. Power supply fuse defective. | 1. Replace power supply fuse. |
| | 2. 115 VAC not reaching heater. | 2. Check wiring and fix. |
| | 3. Ground connections not secure to ground screw or gas valve. | 3. Secure all ground connections and remove power for 5 seconds. |
| | 4. Internal transformer defective. | 4. Replace internal transformer. |
| | 5. Diagnostic light defective. | 5. Replace diagnostic light. |
| Pressure switch does not close or sticks closed / Diagnostic light four flashes. 4 FLASHES | 1. Inlet or exhaust piping not the proper size and length. (Refer to manual.) | 1. Replace piping as required. |
| | 2. Inlet or exhaust termination fittings not to factory specifications. | 2. Replace fittings as required. |
| | 3. Inlet or exhaust blocked. | 3. Clear blockage. |
| | 4. Airflow tubing or snubber orifice blocked in one or both tubes. | 4. Clear blockage. |
| | 5. Blower wheel dirty or damaged. | 5. Clean or repair wheel. |
| | 6. Airflow pressure switch malfunction. | 6. Correct gas pressures or replace airflow pressure switch. |
| Ignitor does not spark / Diagnostic light one flash. 1 FLASH | 1. 24 VAC not reaching the Ignition Detection Control (IDC) due to loose wire or connector. | 1. Repair loose wire or connector. |
| | 2. 24 VAC not reaching the Ignition Detection Control (IDC) due to defective internal transformer. | 2. Replace internal transformer. |
| | 3. High-voltage wire loose or damaged. | 3. Secure high-voltage wire or replace ignitor. |
| | 4. Ignition Detection Control (IDC) defective. | 4. Replace IDC box. |
| Burner does not ignite. (There are three trials-for-ignition before the IDC goes into lockout) / Diagnostic light two flashes. 2 FLASHES | 1. Gas supply not turned on. | 1. Open all manual gas supply valves. |
| | 2. Ignitor not sparking at the tips. | 2. Measure spark gap and adjust gap as necessary to 5/32" [0.156" (3.96mm)]. |
| | 3. Ignitor not sparking at correct gap. | 3. Replace ignitor. |
| | 4. Gas inlet pressure not correct. (See serial plate). Gas inlet piping not sized correctly. | 4. Replace inlet gas piping with correct size pipe. |
| | 5. Gas inlet pressure not correct. (See serial plate). Gas supply regulator not set correctly. | 5. Adjust gas supply regulator to set inlet pressure to proper level. (See serial plate). |
| | 6. Gas supply regulator sticking. | 6. Replace gas supply regulator. |
| | 7. Combination gas valve not in the ON position. | 7. Turn combination gas valve to the ON position. |
| | 8. Ignition Detection Control (IDC) not sending 24VAC to combination gas valve. | 8. Replace IDC box. |
| | 9. Combination gas valve defective. | 9. Replace combination gas valve. |
| | 10. Combination gas valve outlet (manifold) pressure not correct. (See serial plate). | 10. Adjust combination gas valve regulator to set inlet (manifold) pressure to proper level. |
| | 11. Main orifice blocked by spider web, etc. | 11. Clear blockage. |
| | 12. Gas orifice or air orifice not correct size. | 12. Install correct size gas orifice or air orifice. |
| Spark does not stop when the burner ignites / Diagnostic light three flashes. 3 FLASHES | 1. Power supply not grounded to a true earth ground. | 1. Install a true earth ground to the power supply. |
| | 2. Flame sensor wire loose or damaged. | 2. Secure flame sensor wire or replace wire harness to IDC box. |
| | 3. Flame signal insufficient. | 3. Check gas inlet and manifold pressures compared to the possible causes in the previous symptom where the burner does not ignite. |
| | 4. Ignition Detection Control (IDC) is defective. | 4. Replace IDC box. |
| Burner does not stay lit until the thermostat is satisfied / Diagnostic light three flashes. 3 FLASHES | 1. Flame sensor wire is loose or damaged. | 1. Replace wire harness to IDC box. |
| | 2. Inlet or exhaust partially blocked. | 2. Clear blockage. |
| | 3. Airflow pressure switch erratic or defective. | 3. Consult factory or replace airflow pressure switch. |
| | 4. Flame signal insufficient. | 4. Check gas inlet and manifold pressures compared to the possible causes in the previous symptom where the burner does not ignite. |
| | 5. Ignition Detection Control (IDC) defective. | 5. Replace IDC box. |
| Heater will not turn off. | 1. Thermostat defective. | 1. Replace thermostat. |

REPLACEMENT PARTS

! WARNING !

Any substitutions of factory-installed parts without prior written permission may result in unsafe operation, property damage, personal injury, death, voids CSA design certification, and manufacturer's warranty.

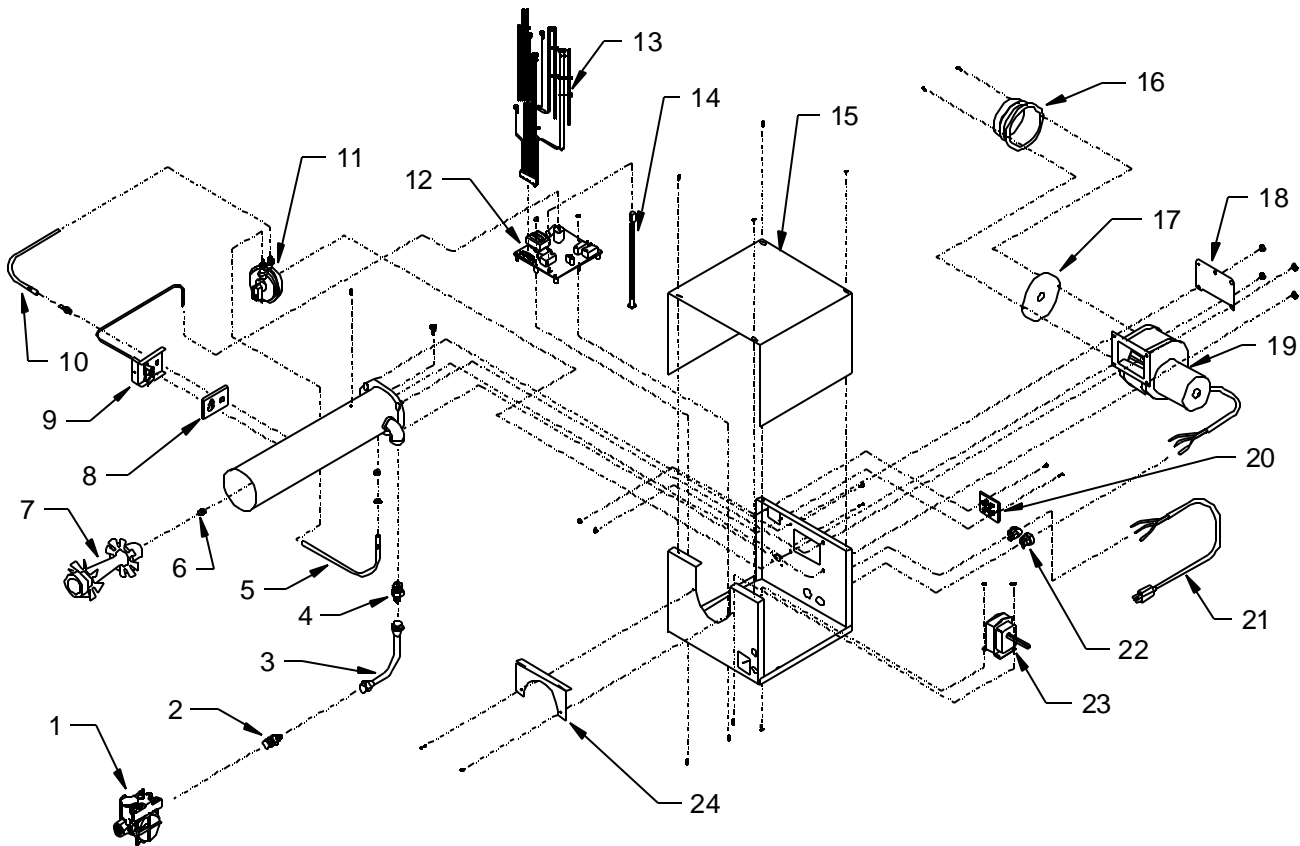

- | | |
|---|---|
| 1. Two-stage gas valve | 12. Ignition detection control (IDC) |
| 2. Gas manifold fitting (at valve) | 13. Wire harness assembly |
| 3. Gas manifold assembly with fittings | 14. Indicator light LED |
| 4. Gas manifold fitting (at burner tube) | 15. Burner cover |
| 5. Airflow switch (combustion) tubing assembly with snubber | 16. Inlet combustion air collar |
| 6. Gas main orifice | 17. Air orifice plate |
| 7. Burner core | 18. Safety chain bracket with nuts |
| 8. Ignitor gasket | 19. Two-stage blower motor |
| 9. Ignitor | 20. Terminal board |
| 10. Airflow switch (exhaust) tubing assembly with snubber | 21. Power cord |
| 11. Airflow switch | 22. Power cord strain relief bushing |
| | 23. Transformer |
| | 24. Burner tube holding bracket with screws |

Due to continuous product improvement, please provide serial and model number prior to ordering replacement parts to assure safe repairs and maintenance.

THIS PAGE INTENTIONALLY LEFT BLANK

FOR SERVICE OR REPAIR, FOLLOW THESE STEPS IN ORDER:

FIRST: Contact the Installer

Name _____

Address _____

Phone _____

SECOND: Contact the Nearest Distributor

Model No.: _____

Unit Serial No.: _____

Date of Installation: _____



P.O. Box 80217, Rochester MI 48308-0217

Toll Free: 1-866-664-3824

FAX: (248) 651-0357

E-mail: sales@sunspanheaters.com

Website: www.sunspanheaters.com